

UC PRO[®]

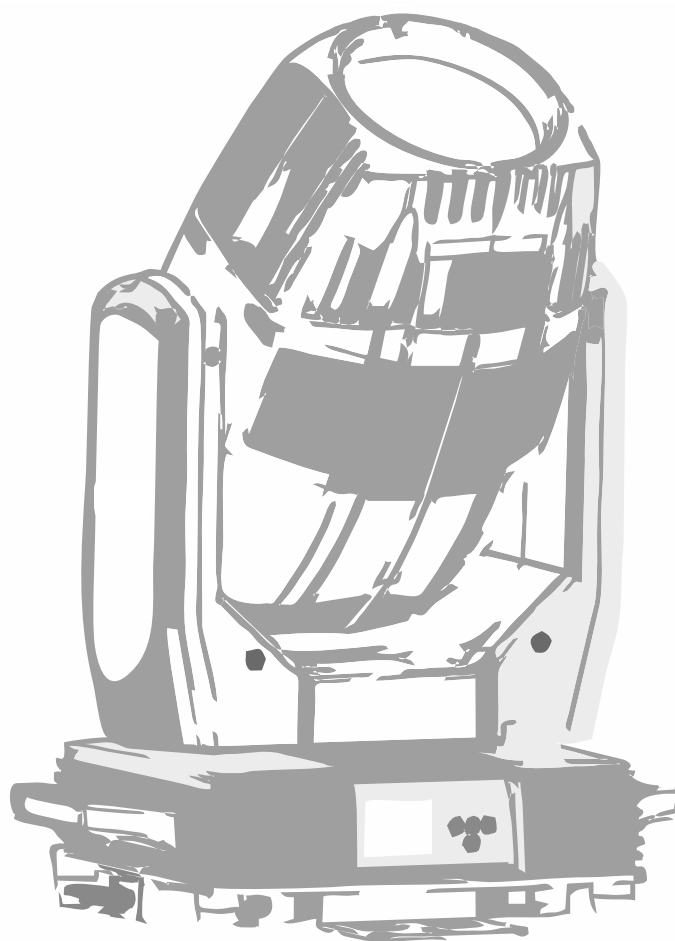

SHARKi
IP66 BEAM Movinglight
User Manual

V1.1

Table of contents

1. SAFETY INSTRUCTIONS	1
2. PRODUCT INTRODUCTIONS	3
2.1 DIMENSIONS	3
2.2 FIXTURE OVERVIEW	4
2.3 ACCESSORIES	4
3. PACKING AND SHIPPING	5
3.1 PROTECTION LOCK	5
3.2 UNPACKING	5
3.3 PACKING AFTER USE	5
4. INSTALLATION	6
4.1 CLAMPS INSTALLATION	6
4.2 DEVICE INSTALLATION	6
4.3 LAMP FITTING AND ADJUSTMENT	7
5. POWER / CONTROL CONNECTION	8
5.1 POWER CONNECTION	8
5.2 CONTROL CONNECTION	8
5.3 TESTING	8
6. CONTROL PANEL	9
6.1 PANEL INSTRUCTION	9
7. TECHNICAL SPECIFICATION	10
8. GOBOS AND COLORS	12
8.1 GOBOS	12
8.2 COLORS	12
9. MENU STRUCTURE	13
10. DMX PROTOCOL	16
11. SYSTEM WIRING DIAGRAM	18
12. MAINTENANCE AND TROUBLESHOOTING	19
12.1 CLEANING AND MAINTENANCE	19
12.2 TROUBLESHOOTING	19

1. Safety instructions

Before using the fixture, read the latest version of the product user manual, paying particular attention to the safety instructions.



The manufacture of this fixture, are not responsible for damages, resulting from misuse of this fixture, due to the disregard of the information printed in this user manual.



DANGER!
Hazardous voltage. Risk of lethal or severe electric shock



WARNING!
Wear protective eyewear. Never look directly into the light source.



WARNING!
Burn hazard. Hot surface. Do not touch.



Only to direct mounting on non-combustible surfaces.



Replace all cracked glass shields.

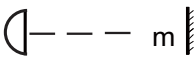

Minimum distance to lighted objects.

$t_a \dots ^\circ\text{C}$ Maximum ambient temperature.

$t_c \dots ^\circ\text{C}$ Maximum temp of the external surface.

General guidelines ⚠

- This product has a protection rating of IP66.
- Never open this fixture while in use.
- The fixture should be kept clean. DO NOT operate the fixture in extreme heat or dusty environments. Avoid contact with chemical liquid.
- Minimum distance to lighted objects must be 49.21 feet (15m).
- Maximum temp of the external surface 194°F (90°C).
- Maximum ambient temperature 113°F (45°C).
- Minimum distance of inflammable materials from the surface 1.6 feet (0.5m).
- Lamp should be changed if damaged or distorted in shape due to extreme heat.
- Cover, prism or LCD Menu Function Display with visible damages such as cracks or scratches must be replaced to ensure performance of the fixture.
- Disconnect the fixture from power before changing any parts or accessories.
- Basic insulation should be maintained between the controllable device and the product power supply.
- Make sure that the installation area can hold a minimum point load of 10 times the weight of all installed fixtures, clamps, cables, auxiliary equipment, etc. Check that the cover, clamps and locks are undamaged. Certified safety cables must always be used when installing the fixture.
- The fixture is only intended for installation, operation and maintenance by qualified professional. Instructions stated in the manual must be complied.
- The fixture must be kept in a well-ventilated place at least 50 cm away from any wall surface. Check if the fans or ventilation openings are unblocked.
- This fixture uses discharge lamp. To avoid reducing the lamp's life, wait at least 15 minutes after powering off to allow the unit to cool down before handling.
- Broken or damaged cables and light source can only be fixed or changed by certified technicians, certified local distributors or the manufacturer to ensure operational safety.
- Do not stick filters or other materials onto the lens. Do not modify the fixture or install other manufactured parts.

2. Production instructions

2.1 Dimensions

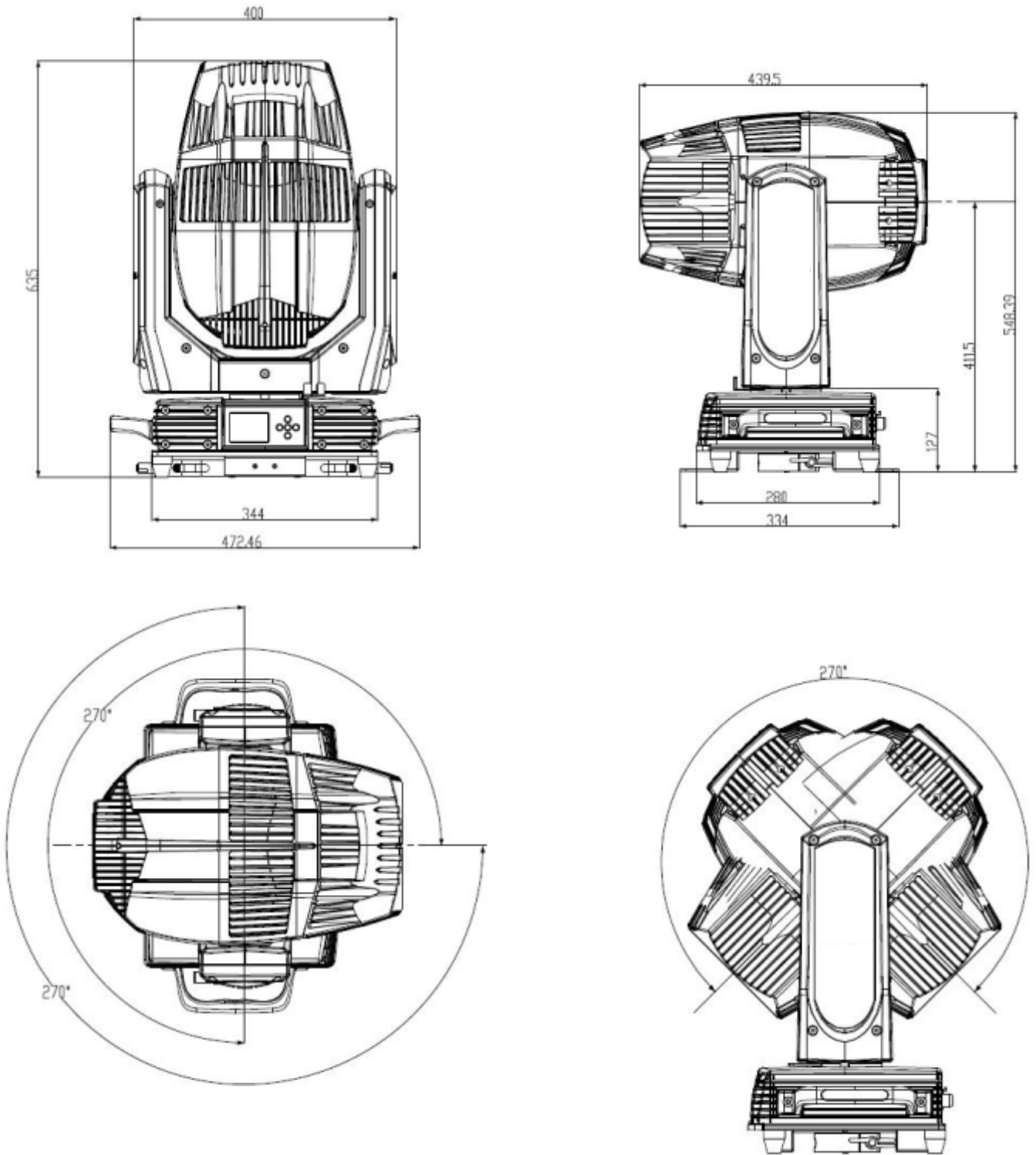

2.2 Fixture overview

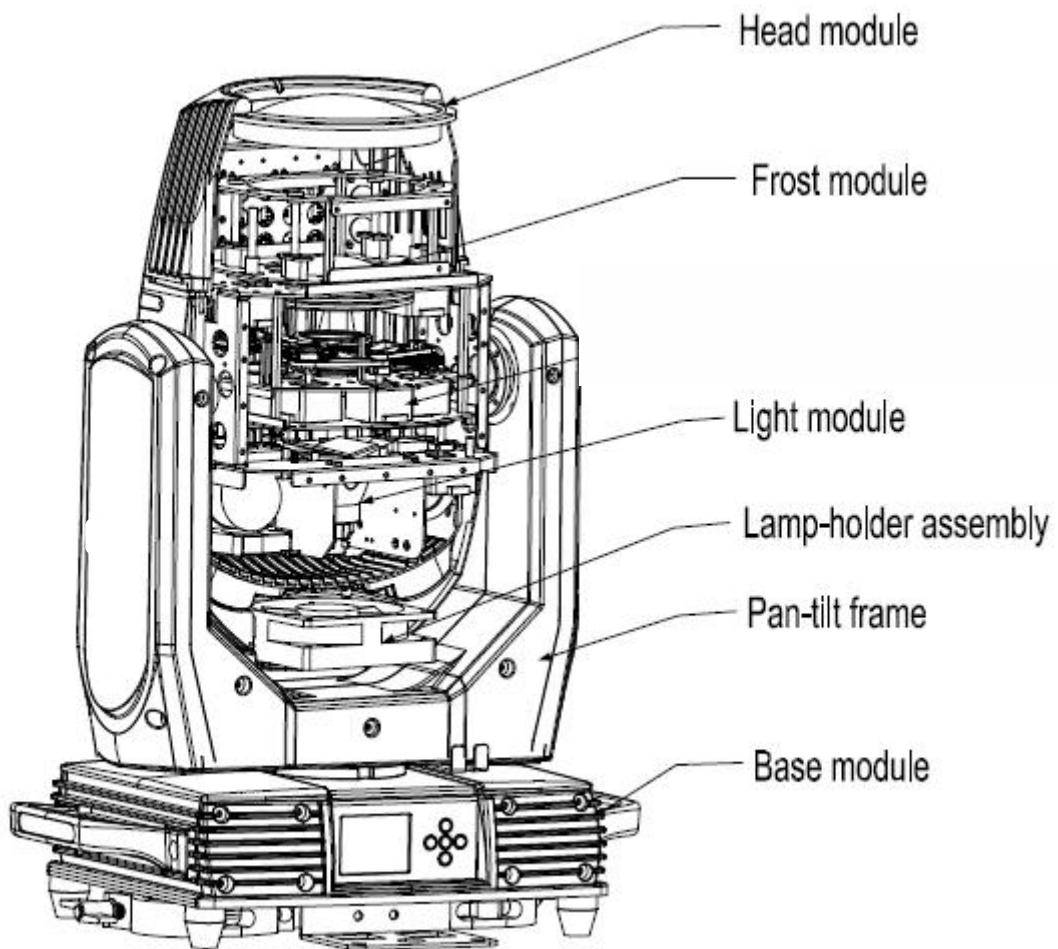

2.3 Accessories

Item	Qty	Unit	Remark
User Manual	1	Pc	--
Clamps	2	Set	Hanging integrated folding lamp, Load weight 200KG
Safety cable	1	Pc	Φ5*60cm 7*19 pc with hook Material: Steel
5-pins signal line	1	Set	--
Power cable	1	Set	1.5*2.5mm ²

3. Packing and shipping

3.1 Protection lock

Pan and tilt locks are equipped to ensure safe transportation.

PAN: 4 lock positions are located evenly on the Pan.

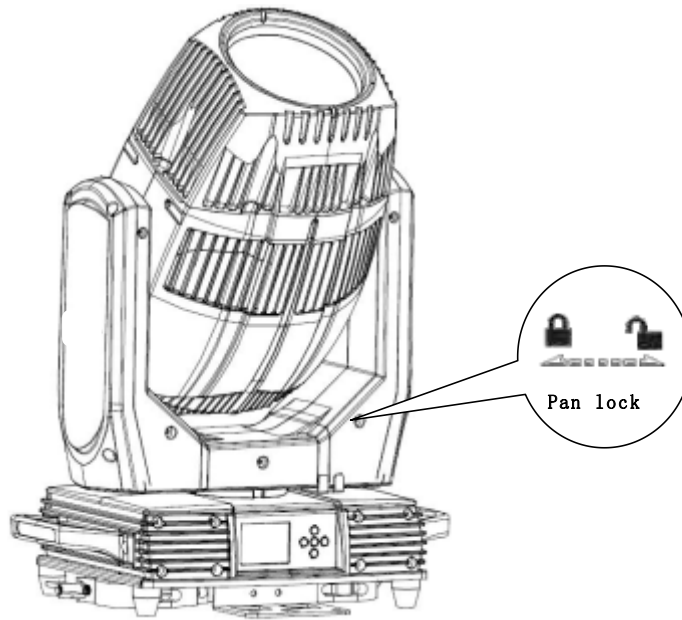

3.2 Unpacking

⚠ Notes

All products are quality controlled and checked for any faults before they are dispatched to customers. If the fixture is damaged during delivery, the customer must notify the shipper and manufacturer to file a damage insurance claim. Photographic evidence of the damage must be provided.

Flight-Case: Open the cover of the flight-case and remove the plastic packing bags. Hold the handles of the fixture firmly and take it out carefully.

Cardboard box: Open the box and take out the whole set of packaging foam which contains both the fixture and its accessories. Remove the foam from the top, put away the accessories, and then take out the fixture wrapped in the plastic bag.

⚠ Notes

Check if the pan and tilt are unlocked before connecting the fixture to power.

3.3 Packing after use

1. Switch off the fixture and wait for at least 5 minutes before disconnecting it from AC power. Cool down the fixture for at least 15 minutes before packing.
2. Lock pan and tilt.
3. Flight case: Wrap the fixture in plastic bags. Hold it by the handles, and then carefully place it inside the flight case along with all the accessories. Close the cover. Only 3 layers are allowed when piling up the flight cases. Do not upside down.
4. Cardboard box: Wrap the fixture in plastic bags. Put it in the packaging foam along with all the accessories. Place the other set of packaging foam on top then carefully put it inside the cardboard box.

4. Installation

4.1 Clamps installation

The fixture can be placed on the stage or mounted on the truss facing any direction. Attach the clamps to the mounting position on the base of the fixture.

Warning : Use two clamps when mounting the fixture. Turn the screws attached to each clamp a 1/4 turn clockwise to lock. Always remember to use the safety cable which goes through the mounting hole on the base. Do not attach the safety cable on the handle.

4.2 Device installation

1. Make sure there is no damage on the clamps or safety cables before installation.
2. The clamp is mounted on the chassis of the fixture. Horizontally insert the clamp into the mounting holes of the chassis. Fasten the clamp tightly by a 1/4 turn clockwise. Fix another clamp in the same way.
3. Check if pan is unlocked before connecting the unit to AC power.

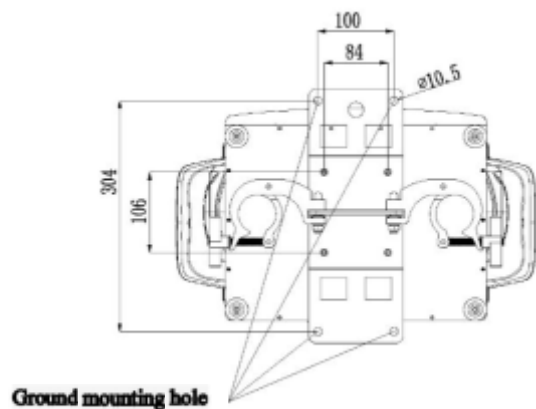
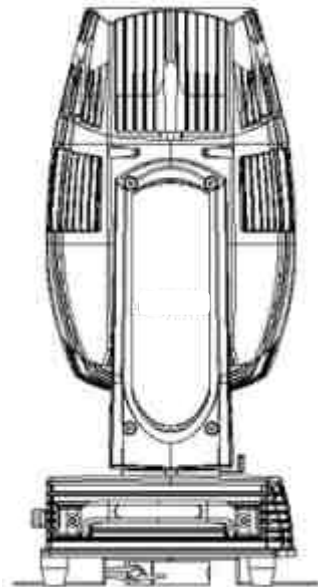
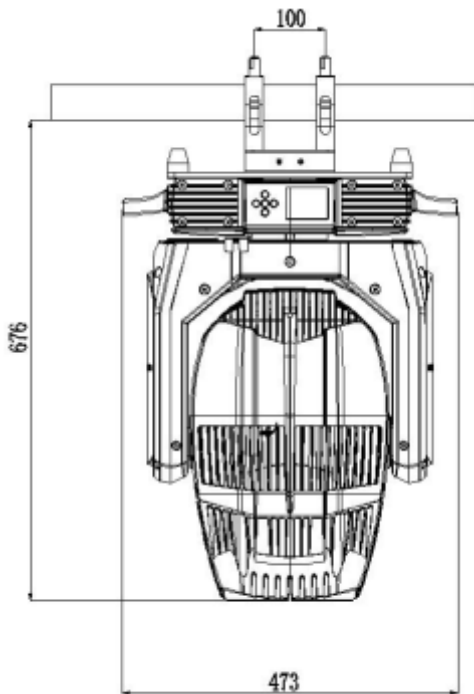

4.3 Lamp fitting and adjustment

1. Disconnect the fixture from AC power. Cool down the fixture. Set the Tilt lock in a horizontal position.
2. Remove the lamp holder lower cover and plug out the waterproof terminal when disassemble the bulb, then loosen the fixed plate and take out the bulb.
3. Put the bulb into the fixed plate, then press the bulb clockwise with the fixed plate when install the bulb, observe the bulb spot and adjust it after lighted the bulb. Finally, plug in the waterproof fan and lamp holder lower cover.

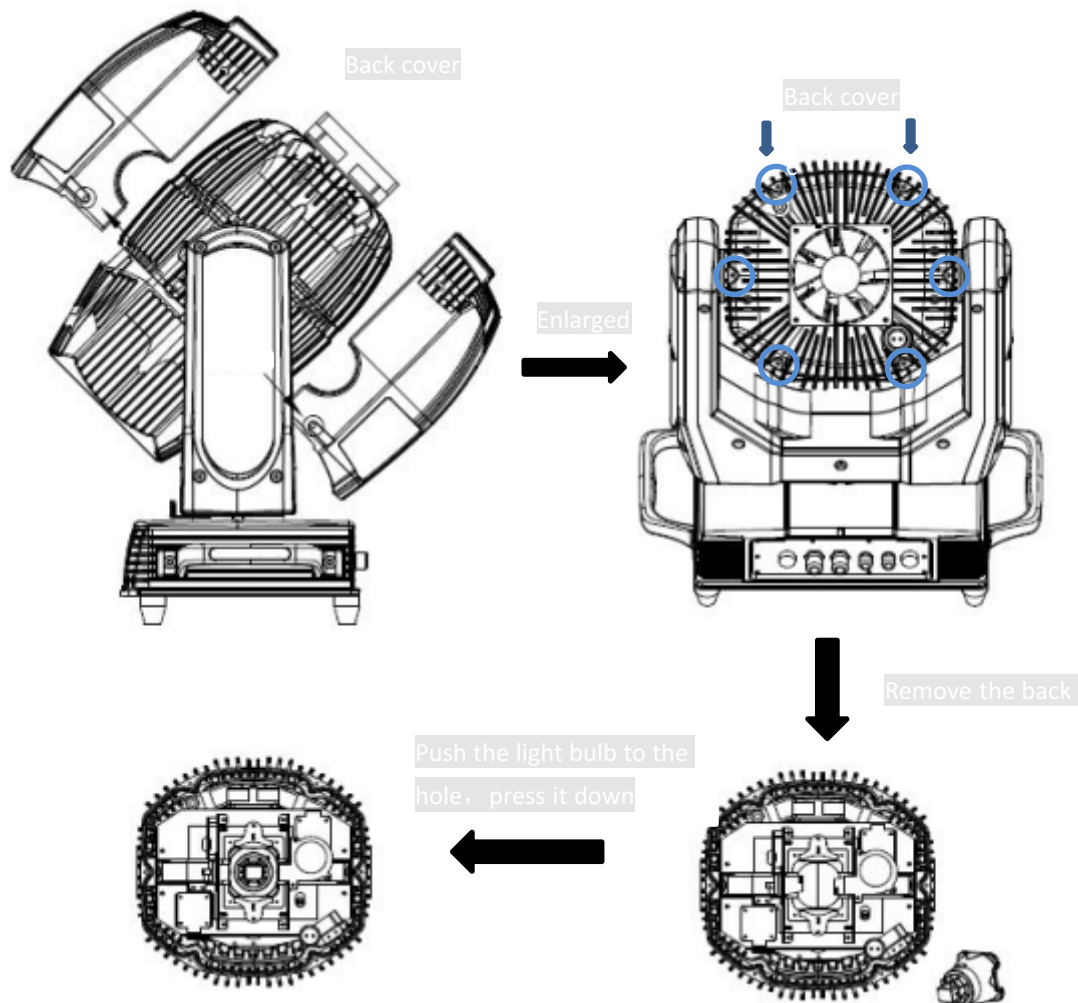

Note

The fixture is equipped with PHILIPS MSD Platinum Flex 300S, which is featured with high efficiency and short-arc characteristic, such as a stable 7200K color-temperature and average lifespan of 6000h.

Note

1. Fitting another type of lamp will cause potential damage to the fixture. Change the lamp before it reaches its lifespan. Read the guidelines in the package carefully when fixing the lamp.
2. To avoid any impact on the beam, do not touch the bulb with your bare hands. The lamp must be kept clean with the use of the clean paper contained in its package

5. Power/ Control connection

5.1 Power connection

Connection method:

- L (Live) Brown wire
- E (Earth) Yellow / Green bi-color wire
- N (Neutral) Blue wire
- The voltage and frequency of the power source must be in compliance with the ones marked on the fixture. It is strongly recommended that each fixture are to be connected to the power source separately so that they can be switched on / off individually.

5.2 Control connection

The fixture has 5-pin XLR connectors for DMX data input and output as shown below. Connection between the console and fixture, and between fixtures must be made with 2 core screened DMX signal cable. Maximum connecting distance of signal cable is 150 meters. Additional DMX512 signal-amplifier is recommended for longer distance

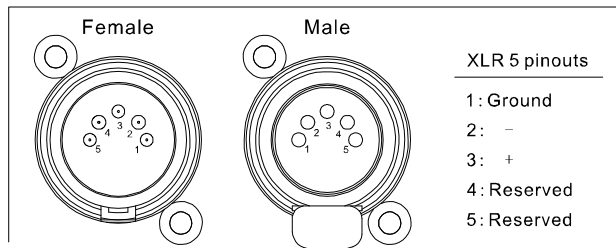

Connect the Console's DMX OUTPUT to the first fixture's DMX INPUT, then the first fixture's DMX OUTPUT to the second fixture's DMX INPUT and so on. It is recommended not to connect more than 32 units on a single DMX universe. On the last fixture's output connect a DMX terminator. (The terminator is a 5-pin XLR connector with a 1/4W and 120Ω resistor between the pin 2 and pin 3) as shown below:

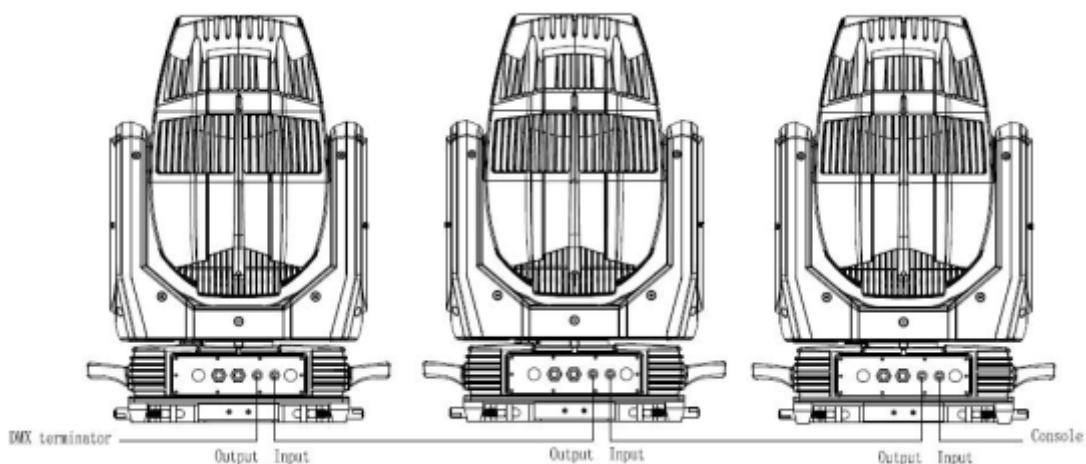

5.3 Testing

Connect the fixture to AC power. Check if the lamp is on and the fixture is independently controllable before putting into operation.

6.Controlpanel Panelinstruction

6.1

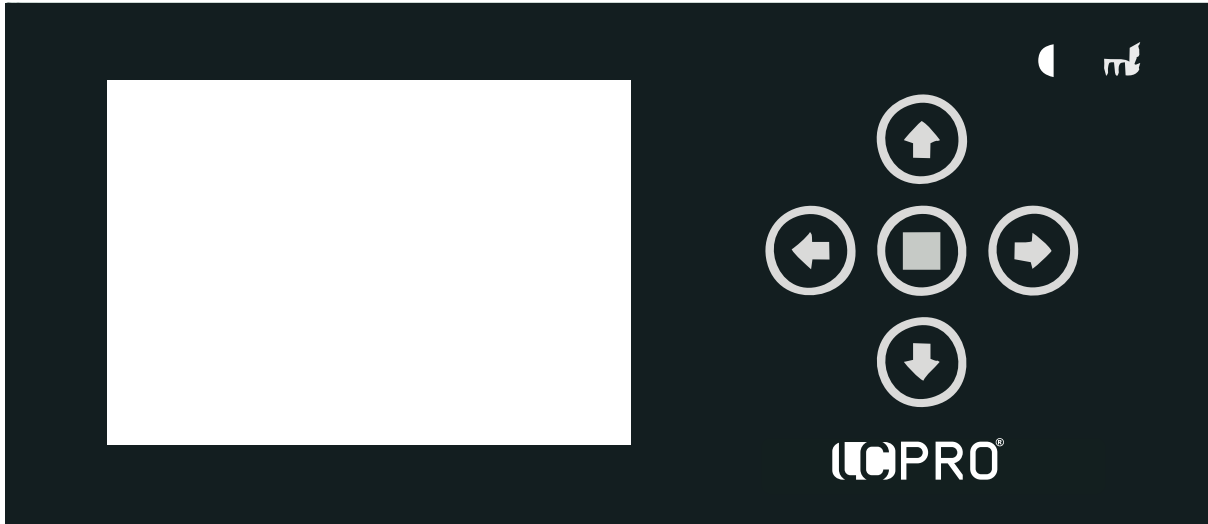

The control panel features touch-sensitive buttons and LCD digital display for quick and easy setup of address code and functions menu.

Press UP or DOWN to view or select the function menu.

Press CENTER to choose a function and enter into corresponding sub menu. Each menu represents a specific function of the fixture.

Press RIGHT to select the specific function and save the changes or enter into the submenu, then press UP or DOWN to change the value of the selected function (increase or decrease).

Press LEFT to return to the previous menu or exit.

Button panel indicator:

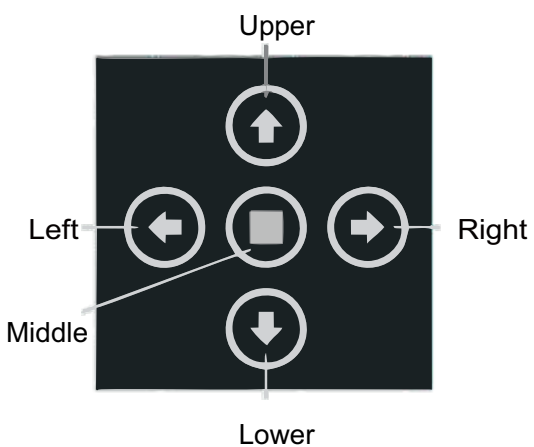

7. Technical specification

- **Optical**

Light source: PHILIPS MSD Platinum Flex 300S

Expected average lifetime: 6000 h

Color temperature correction: 7200K

Zoom: 2°

CRI: Ra ≥ 80

Focus: High-precision glass lenses, electronic linear HD focus

Prism: 1 pc tip 8-facet prism, 1 pc tip 16-facet prism, prisms can be controlled independently ,
or can be combined to make abundant beam effects

Frost: 1-independent frost effect

- **Gobo**

Fixed gobo wheel: 12 gobos + open, CW/CCW rotation, variable speed

- **Color**

Color wheel: 14 colors + open, split color, CW/CCW rotation, “Rainbow effect” in both directions

- **Electrical**

Power input, nominal: AC 100-240V 50/60Hz

Max. Power consumption: 580W, max current: 2.9A, PF: 0.99

Power supply unit: Auto-ranging electronic SMPS

Main fuse: 250V/6.3A

Ballast: Electronic

Power input: Self-contained power cord

DMX data input/output: Chassis 5-pin (in/out)

- **Control and programming**

Control channels (DMX): 15/12/16

Protocol: DMX-512 RDM

Display: LCD

- **Physical / Installation**

Weight: 24Kg (52.9lbs.)

IP rating: IP66

Material: Aluminum, steel, plastic

Mounting points: Four quarter-turn locking points + attachment points for safety wire

- **Dynamic effects**

Pan/Tilt movement: 540°/270°

Iris: Motorized adjustable iris, wide range of variable pulse effects

Strobe: 1-20Hz, synchronized, pulse effects

Dimmer: 0-100%, mechanical dimming

- **Thermal**

Operating range: 5°F to 113°F (-15°C to +45°C)

Startup range: -13°F to 113°F (-25°C to +45°C)

Storage range: -40°F to 140°F (-40°C to +60°C)

Cooling: Active fan

- **Certification and Safety**

EMC: EN 55103-1:2009, EN 55103-2:2009, EN 61000-3-2:2006+A2:2009, EN 61000-3-3:2013,
GB/T 17743-2007, GB 17625.1-2012

Safety: EN 60598-2-17:1989/A2:1991, GB 7000.1-2015, GB 7000.217-2008

- **Photometric**

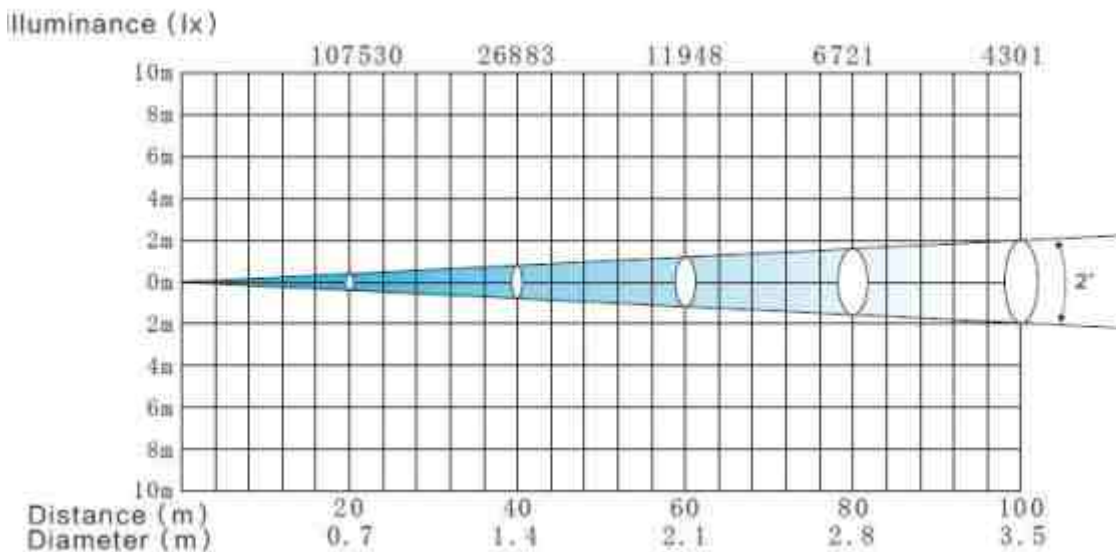

- **Other features**

- Enhanced stability of the fixture due to the wide input voltage AC/DC switching power supply which both reduces the impact of power and voltage fluctuations, and removes the restriction of voltage and frequency variations in different countries.
- Automatic energy saving: when the shutter or CMY is closed, power consumption will be reduced automatically with the photoelectric tracking induction technology.
- Sleep mode: uses the most advanced technology to remotely activate sleep mode. When the fixture is disconnected from signal, the sleep mode is enabled automatically to make it more stable and safer. Sleep time can be customized.
- Power setting: built-in continuous rechargeable battery, allowing setting functional data via LCD interface without power connection

8.Gobos and colors

8.1 Gobos

One fixed gobo wheel: 12 gobos + open, CW/CCW rotation, variable speed

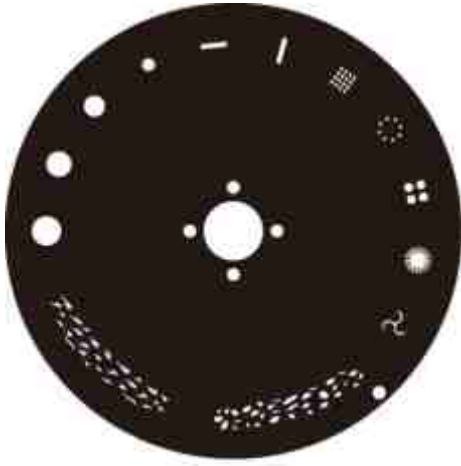

Fixed gobo wheel

8.2 Colors

Color wheel: 14 colors + open, split color, CW/CCW rotation, "Rainbow effect" in both directions

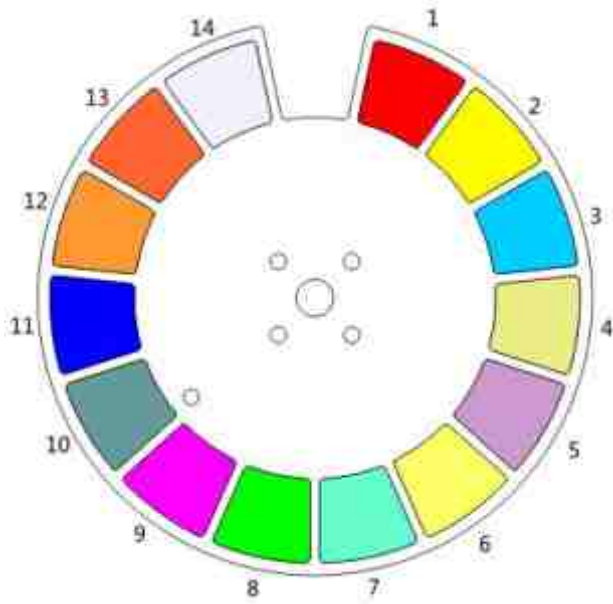

1.Red	2.Yellow	3.Blue	4.Yellow	5.Purplishred	6.Lightyellow
7.Bluegreen	8.Green	9.Rosered	10.Lavender	11.Fluorescence	12.Claybank
13.Brown	14.Coolwhite				

9. Menu structure

Level 1	Level 2	Level 3	Level 4	Info
1.Run setting	1.Address Setting 2.Value Display 3.Auto-Program	Address: 001~ XXX Pan, All, Off Master /Alone		Setting the DMX address Display the channel value Run auto program in master or slave
2.Device Info	1.Time Info	1.This Time 2.Total Time 3.Last Run Hours 4.Lamp On Hours 5.Lamp Off Hours 6.Time Password 7.Clear Last Run 8.Lamp Time Password 9.Clear Lamp Time	XXXXXX Hour XXXXXX Hour XXXXXX Hour XXXXXX Hour XXXXXX Minute Password: XXX Yes/No Password: XXX Yes/No	Since power on time Product total run time Last product run time Lamp on time Lamp close time Clear last time password Clear last time Clear lamp time password Clear lamp time
	2.Temperature	Temperature 1	XXX 'C/'F	Body temperature
	2.Fans Info.	NO/...		
	4.Err Info	No Err/...		Show this device's status
	5.Software Version	V1.0 RDM Code 0032-xxxxxx		The software version
3.System Setting	1.Status Setting	1.Console Set Address 2.No Signal Status 3.Pan Reverse 4.Tilt Reverse 5.Pan Scan Degree 6.Scan Feedback 7.Standby Time	Enable/Disable Close/Hold/Auto Enable/Disable Enable/Disable 360/540 Enable/Disable Disable/1~120 Min, 30	Address can be changed by console The status while no signal Pan Reverse Tilt Reverse Pan Scan Degree Scan Feedback Standby time
	2.Fan Speed	1.Smart Control 2.High Speed 3.Low Speed		Auto fans speed Fans high speed Fans low speed
	3.Display Setting	1.Backlight Time 2.Keyboard Lock 3.Brightness Set 4.Language Select	1~80 Min/Disable Enable/Disable 15~100% 80% Chinese/English	Backlight off time Press <menu> 3s to unlock Back lightness of screen Change the language

		5.Auto Screen Set	Off/On/Auto	Screen change Setting
	4.Temperature Unit	Celsius Fahrenheit		Temperature unit
	5.Value Default	Pan.....	Pan =XXX	The default value after power on
	6.Wireless Devi	Wireless Off Wireless On Wireless Trans. Wireless Reset		Wireless off Wireless on Wireless transfer DMX data to another Wireless reset
	7.Restore Default	Yes/No		Restore to default value
5. Moto Reset	1.System Reset 2.Scan Reset 3.ColorReset 4.Gobo Reset 5.Strobe Reset 6.Other Reset			System reset Pan and tilt motor reset Color motor reset All gobo motor reset Strober motor reset All other motor reset
6.Chann el Adjust	1.Test Mode	Pan.....		Every channel test
	2.Manual Mode	Pan :	Pan =XXX :	Manual control
	3.Adjust Mode	Input Password Pan :	Password=XXX Pan=XXX :	The password of adjust mode Fixed all begin position
7.Chann el Setting	1.Channel Mode	Standard Mode Basic Mode Extended Mode Custom Mode A Custom Mode B Custom Mode C		Standard channel mode (15ch) Basic channel mode (13ch) Extended channel mode (17ch) Custom channel mode A Custom channel mode B Custom channel mode C
	2.Set Custom Mode1 3.Set Custom Mode2 4.Set Custom Mode3	Max Channel Pan :	Channel = XX Pan = CH01 :	Change the channel order
8.Progra m Edit	1.Select Group	1.Program Unit 1	Auto-Program 1 ~10	Choose build-in program for slave 1
		2.Program Unit 2	Auto-Program 1 ~ 10	Choose build-in program for slave 2
		3.Program Unit 3	Auto-Program 1 ~	Choose build-in program for slave

			10	3
2.Program Edit	Auto-Program1 : Auto-Program10	Run Step 1=Scene xxx Step 8=Scene xxx	Choose the scene for program 1 : Choose the scene for program 10	
3.Scene Edit	Scene Edit:001-250	Pan,.....Pan=xxx Scene Time=xxx Input By Console	Edit the channel DMX Edit the scene time Get scene DMX form console	
4.Record Scene	Start Scene: XX	Start Scene: XX End Scene: XX	Record scene form console	

*Settings hight lighted in light grey are default values

10. DMX Protocol

DMX mode			Name	DMX value		DMX percentage		Function	Default DMX Value
Standard (15ch)	Simplified (12ch)	Standard (16ch)							
1	1	1	Strobe/ Shutter	0	31	0.0%	12.2%	Closed	0(0%)
				32	63	12.5%	24.7%	Open	
				64	127	25.1%	49.8%	Synchronous strobe from slow to fast	
				128	159	50.2%	62.4%	Open	
				160	223	62.7%	87.5%	Random strobe from slow to fast	
				224	255	87.8%	100.0%	Open	
2	2	2	Intensity	0	255	0.0%	100.0%	No light → Full light	0(0%)
3		3		0	65535	0.0%	100.0%	Intensity fade, fine (LSB)	
4	3	4	Color wheel	0	7	0.0%	2.7%	Open	0(0%)
				8	15	3.1%	5.9%	Color 1	
				18	23	6.3%	9.0%	Color 2	
				24	31	9.4%	12.2%	Color 3	
				32	39	12.5%	15.3%	Color 4	
				40	47	15.7%	18.4%	Color 5	
				48	55	18.8%	21.6%	Color 6	
				56	63	22.0%	24.7%	Color 7	
				64	71	25.1%	27.8%	Color 8	
				72	79	28.2%	31.0%	Color 9	
				80	87	31.4%	34.1%	Color 10	
				88	95	34.5%	37.3%	Color 11	
				96	103	37.6%	40.4%	Color 12	
				104	111	40.8%	43.5%	Color 13	
				112	127	43.9%	49.8%	Color 14	
				128	187	50.2%	73.3%	Color1 continuous rotation CW from fast to slow	
188	195	73.7%	76.5%	Stop					
196	255	76.9%	100.0%	Color1 continuous rotation CCW from slow to fast					
5	4	5	Gobo wheel (static)	0	15	0.0%	5.9%	Open gobo	0(0%)
				18	18	6.3%	7.1%	Gobo 1	
				19	21	7.5%	8.2%	Gobo 2	
				22	24	8.6%	9.4%	Gobo 3	
				25	27	9.8%	10.6%	Gobo 4	
				28	30	11.0%	11.8%	Gobo 5	
				31	33	12.2%	12.9%	Gobo 6	
				34	36	13.3%	14.1%	Gobo 7	
				37	39	14.5%	15.3%	Gobo 8	
				40	42	15.7%	16.5%	Gobo 9	
				43	45	16.9%	17.6%	Gobo 10	
				46	48	18.0%	18.8%	Gobo 11	
				49	51	19.2%	20.0%	Gobo 12	
				52	53	20.4%	20.8%	Open gobo	
				54	59	21.2%	23.1%	Gobo 1 shake	
				60	65	23.5%	25.5%	Gobo 2 shake	
				68	71	25.9%	27.8%	Gobo 3 shake	
				72	77	28.2%	30.2%	Gobo 4 shake	
				78	83	30.6%	32.5%	Gobo 5 shake	
				84	89	32.9%	34.9%	Gobo 6 shake	
90	95	35.3%	37.3%	Gobo 7 shake					
96	101	37.6%	39.6%	Gobo 8 shake					
102	107	40.0%	42.0%	Gobo 9 shake					
108	113	42.4%	44.3%	Gobo 10 shake					

DMX mode			Name	DMX value		DMX percentage		Function	Default DMX Value
Standard (15ch)	Simplified (12ch)	Standard (16ch)							
5	4	5	Gobo wheel (static)	114	119	44.7%	46.7%	Gobo 11 shake	0(0%)
				120	125	47.1%	49.0%	Gobo 12 shake	
				126	127	49.4%	49.8%	Open gobo	
				128	167	50.2%	73.3%	Gobo wheel continuous rotation CW from slow to fast	
				198	195	73.7%	76.5%	Stop	
				196	255	76.9%	100.0%	Gobo wheel continuous rotation CCW from slow to fast	
6	5	6	Focus	0	255	0.0%	100.0%	Near → Far	0(0%)
		7		0	65535	0.0%	100.0%	Focus, fine (LSB)	
7	6	8	Prism1	0	31	0.0%	12.2%	Off	0(0%)
				32	255	12.5%	100.0%	Prism 1	
8	7	9	Prism 2	0	31	0.0%	12.2%	Off	0(0%)
				32	255	12.5%	100.0%	Prism 2	
9	6	10	Prism rotation	0	127	0.0%	49.8%	Prism Indexed	0(0%)
				128	167	50.2%	73.3%	Prism continuous rotation CW from slow	
				168	195	73.7%	76.5%	Stop	
				196	255	76.9%	100.0%	Prism continuous contrarotation CCW from slow	
10	8	11	Frost	0	31	0.0%	12.2%	Off	0(0%)
				32	255	12.5%	100.0%	On	
11	10	12	Pan	0	255	0.0%	100.0%	Pan	0(0%)
12		0		65535	0.0%	100.0%	Pan, fine (LSB)		
13	11	14	Tilt	0	255	0.0%	100.0%	Tilt	46(18.0%)
14		0		65535	0.0%	100.0%	Tilt, fine (LSB)		
15	12	16	Special controls	0	9	0.0%	3.5%	No function	0(0%)
				10	19	3.9%	7.5%	Open light after 5 seconds	
				20	29	7.8%	11.4%	Close light after 5 seconds	
				30	39	11.8%	15.3%	Color wheel half color switch	
				40	49	15.7%	19.2%	Color wheel random positioning	
				50	59	19.6%	23.1%	Reserved	
				60	69	23.5%	27.1%	Reset all motor after 5 seconds	
				70	79	27.5%	31.0%	Scan motor reset after 5 seconds	
				80	89	31.4%	34.9%	All color motor reset after 5 seconds	
				90	89	35.3%	38.8%	All gobo motor reset after 5 seconds	
				100	109	39.2%	42.7%	All strobe motor reset after 5 seconds	
				110	119	43.1%	46.7%	Other motor reset after 5 seconds	
				120	129	47.1%	50.6%	Built-in program 1	
				130	139	51.0%	54.5%	Built-in program 2	
				140	149	54.9%	58.4%	Built-in program 3	
				150	159	58.8%	62.4%	Built-in program 4	
				160	169	62.7%	66.3%	Built-in program 5	
				170	179	66.7%	70.2%	Built-in program 6	
				180	189	70.6%	74.1%	Built-in program 7	
				190	199	74.5%	78.0%	Built-in program 8	
200	209	78.4%	82.0%	Built-in program 9					
210	219	82.4%	85.9%	Built-in program 10					
220	255	86.3%	100.0%	Reserved					

11. System wiring diagram

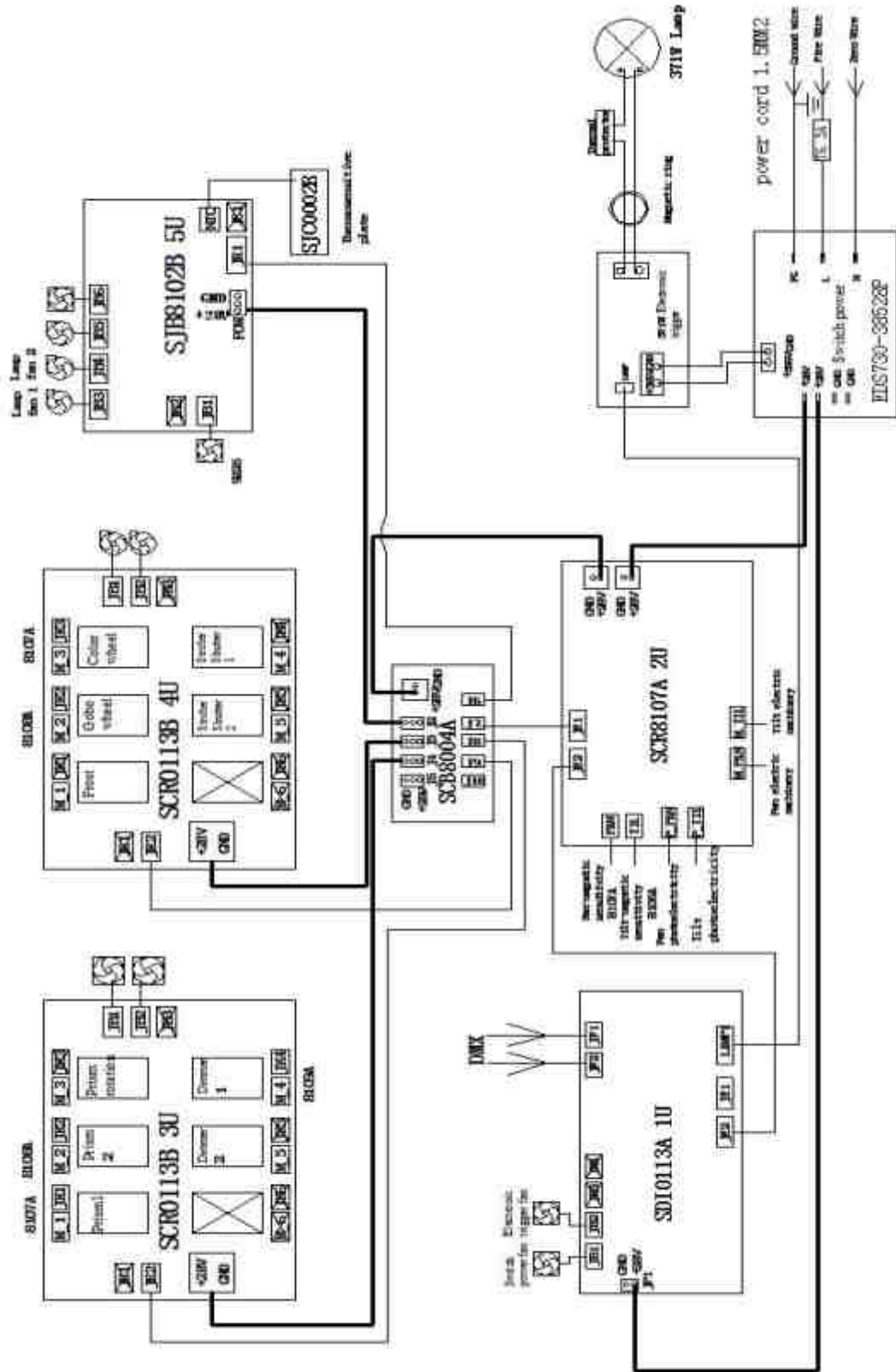

12. Maintenance and Troubleshooting

12.1 Cleaning and maintenance

It is required that the fixture should be kept clean and well maintained to ensure its reliability. Its lifespan mainly depends on the working environment and proper operation.

 Notes: Damage resulted from dust, smoke, oil or improper use is not covered by warranty.

 Notes: Disconnect the fixture from AC power, and let it cool down for at least 15 minutes before opening the housing. Make sure to use a soft cloth to clean the optical components, and be careful, as the coating is easily scratched. Do not use any organic solvent such as alcohol to clean the reflector mirror, dichroic color filters or housing of the fixture.

- If the lens is cracked or otherwise damaged, replace it immediately.
- If the lamp becomes damaged or deformed in any way it must be replaced.
- If the light from the lamp appears dim, this normally indicates that it is reaching the end of its life span and should be changed at once. Aged lamps run to the extremity of their life might explode.
- If fixture does not function, check the fuse on the power socket of the fixture. Replace the fuse of the same specification if it is blown.
- The fixture is equipped with thermal-protection device that will switch off the lamp in case of overheating. If this happens, please check that the fans are not blocked, and clean them if they are dirty. Check whether the fans are operational. If not, call a qualified technician.

12.2 Troubleshooting

Problem	Possible Cause	Suggested Correction
No response after connected to A/C power	Power switch not turned on.	Turn on power switch.
	Take out the fuse and check if it is blown.	Locate the blown fuse. Remove the broken fuse. Insert are placement fuse of the correct amperage
	Abnormal A/C input (A/C power socket, power cables, luminaire power socket).	Replace AC power socket and power cables, and then adjust power socket for proper connection.
	No DC voltage from switching power supply.	Check if the switching power supply has DC voltage output. Replace the switching power supply.
No response or wrong response to the commands of the control system	DMX cables disconnected from fixture's DATA IN connector.	Connect DMX cable to the fixture's DATA IN connector.
	Open circuit or short circuit fault in the DMX cables.	Replace DMX cables as required.
	Wrong DMX address for the fixture in the Control system.	Ensure the address in "Run setting > Address Setting >Address" of the fixture is consistent with the address in the control system.

Problem	Possible Cause	Suggested Correction
	Misuse in “Channel setting > Channel Mode” of the fixture.	Choose the channel mode in “Channel setting > Channel Mode” of the fixture as required by the user
	Malfunctioning of DMX cannon input/output connectors. No input/output voltage to the main control board of the fixture.	Troubleshooting the DMX XLR signal plate of the fixture, replace the main control board of the fixture.
The lamp does not start when switch is turned on	Normal end of lamp life.	Test the lamp in an adjacent fixture which is known to be operating properly and then replace as necessary
	Whether the function of the relay board is intact, whether the signal is normal or not.	Repair or replace.
	Shorted leads between ballast and the lamp	Replace components as required.
	Incorrect ballast output.	Check ballast output to determine if it conforms to lamp requirements. If voltage and current do not stabilize in five to ten minutes warm-up time, ballast output is incorrect and adjustment should be made. Check capacitor wiring, if visibly available, to determine if capacitors are properly wired.
	Incorrect triggers output.	Replace triggers.
The lamp is off unexpected	The fixture is in sleep mode	Should the fixture is not in active use for “standby time”, the sleep mode is enabled automatically to make it more stable and safer, sleep time can be customized.
	Lamp has been operating: cool down time insufficient.	Environmental conditions such as extreme temperatures will have the fixture stop working, the lamps will require a period of time to cool and re-establish optimum starting conditions. Restart time varies with the degree of ventilation built into it, ambient temperature, and draft conditions.
	Overheat ballast resulting in premature failure or damaged ballast.	The ballast incorporate internal automatic-resetting thermal protection, which deactivates the ballast should it overheat. Normal operation resumes once the ballast has cooled sufficiently. Burned-out or failing lamps, or high temperatures in or around the fixture, can cause the ballast to overheat, so we need

Problem	Possible Cause	Suggested Correction
		solve the problem and replace components as required
	Thermostat damaged.	Replace.
Shaking, wrong position, and out of control gobo wheel	No function the connector between gobo wheel motor and drive, loose, damaged, or broken cables connecting the gobo wheel and drive.	Reconnect the gobo wheel motor to the drive, and replace cables as required.
	The gobo wheel motor's drive IC on the PCB might be out of condition.	Replace the drive having the same software version as required.
	Dislocated magnetic tube and positioning magnet, or damaged magnetic tube.	Calibrate the position of the magnetic tube to the positioning magnet, and replace magnetic tube as required
	Shaking motor, wrong rotation angle, losing step or damaged motor	Replace the motor as required.
Decreased brightness, uneven pattern projections	Normal end of lamp life.	Test the lamp in an adjacent fixture which is known to be operating properly and then replace as necessary
	The midline of the lamp is not aligned with the center point of the effect assembly (consisting of the rotating gobo wheel, static gobo wheel, color wheel, strobe, prism, and frost), focus module, and object lens.	Reinstall the lamp. Adjust the lamp position until the midline of the lamp is aligned with the center point of the effect assemblies (consisting of the rotating gobo wheel, static gobo wheel, color wheel, strobe, prism, frost, the focus adjusting module, and the object lens).
	Excessive dusts or smudges on the effect assembly, focus module and objective lens.	Follow the instructions stated in this user manual to clean the effect assembly, focus module and objective lens.
	Damaged or deformed effect assembly, focus module or objective lens.	Replace the damaged or deformed components
Wrong color	Normal end of lamp life	Test the lamp in an adjacent fixture which is known to be operating properly and then replace as necessary
	Excessive dusts or smudges on the rotating gobo wheel or color wheel.	Follow the instructions stated in this user manual to clean the rotating gobo wheel or color wheel.
	Rotating gobo wheel, color wheel with coating wearing off, damages or deformation	Replace the worn-off, damaged or deformed rotating gobo wheel and color wheel

Problem	Possible Cause	Suggested Correction
Non-clear shape	Excessive dusts or smudges on the rotating gobo wheel or color wheel	Follow the instructions stated in this user manual to clean the rotating gobo wheel or color wheel.
	Excessive dusts or smudges on the focus module or objective lens	Follow the instructions stated in this user manual to clean the focus module or objective lens
	Damaged or deformed focus module or objective lens.	Replace the damaged or deformed focus module or objective lens.



LCPRO® is a brand of:

LC Handels GmbH
 Rothenberger Str. 52
 48493 Wettringen

www.lcpro.de
trade@lcpro.de
 02557-999 90-70

WEEE-Reg.: DE 40398897