



ARTISTE MONETTM

user manual

©2022 ELATION PROFESSIONAL all rights reserved. Information, specifications, diagrams, images, and instructions herein are subject to change without notice. ELATION PROFESSIONAL logo and identifying product names and numbers herein are trademarks of ELATION PROFESSIONAL. Copyright protection claimed includes all forms and matters of copyrightable materials and information now allowed by statutory or judicial law or hereinafter granted. Product names used in this document may be trademarks or registered trademarks of their respective companies and are hereby acknowledged. All non-ELATION brands and product names are trademarks or registered trademarks of their respective companies.

ELATION PROFESSIONAL and all affiliated companies hereby disclaim any and all liabilities for property, equipment, building, and electrical damages, injuries to any persons, and direct or indirect economic loss associated with the use or reliance of any information contained within this document, and/or as a result of the improper, unsafe, insufficient and negligent assembly, installation, rigging, and operation of this product.

Elation Professional USA | 6122 S. Eastern Ave. | Los Angeles, CA. 90040
323-582-3322 | 323-832-9142 fax | www.elationlighting.com | info@elationlighting.com

Elation Professional B.V. | Junostraat 2 | 6468 EW Kerkrade, The Netherlands
+31 45 546 85 66 | +31 45 546 85 96 fax | www.elationlighting.eu | info@elationlighting.eu

Elation Professional Mexico | AV Santa Ana 30 | Parque Industrial Lerma, Lerma, Mexico 52000
+52 (728) 282-7070

DOCUMENT VERSION



Due to additional product features and/or enhancements, an updated version of this document may be available online. Please scan the QR Code with your mobile device or visit www.elationlighting.com for the latest revision/update of this manual, before installation and/or programming.

Date	Document Version	Software Version ≥	DMX Channel Modes	Notes
05/14/19	1.0	1.3.3	40 / 67	Initial release.
09/25/19	1.2	1.4.0	No Change	Removed E-FLY options from System Menu.
10/10/19	1.4	1.3.4 1.4.1	No Change	Added Low Noise Modes to Control Channel.
10/25/19	1.6	N/C	No Change	Added Gobo washer part # and note.
04/07/20	1.8	1.3.4 1.4.1	No Change	Updated Power Consumption Specs.
06/22/20	2.0	N/C	No Change	Updated Thermal & box contents.
12/01/20	2.2	1.3.7 1.4.5	No Change	Updated primary/secondary Modes
03/01/21	2.4	N/C	No Change	Added Transportation & Handling Precaution
05/24/22	2.6	N/C	No Change	RDM codes added & IDS added
08/24/22	2.8	N/C	No Change	Updated RDM information

CONTENTS

General Information	4
Warranty Returns (USA Only)	5
Safety Guidelines	6
Maintenance Guidelines	8
Fixture Overview	9
Colors, Gobos, Animation	10
SpectraColor Guide	11
Fan Modes and Low Noise Operation	12
Custom Gobos	13
GOBO Installation	14
Installation Guidelines	19
Remote Device Management (RDM)	23
System Menu	24
Dimmer Curves	34
DMX Channel Functions and Values	35
Error Codes	48
Specifications	49
Optional Accessories	52

GENERAL INFORMATION

INTRODUCTION

Please read and understand the instructions in this manual carefully and thoroughly before attempting to operate this device. These instructions contain important safety and use information. **This product is intended to be used by professionally trained personnel only, and is not suitable for private use.**

UNPACKING

Every device has been thoroughly tested and has been shipped in perfect operating condition. Carefully check the shipping carton for damage that may have occurred during shipping. If the carton is damaged, carefully inspect the device for damage, and be sure all accessories necessary to install and operate the device have arrived intact. In the event damage has been found or parts are missing, please contact our customer support team for further instructions. Please do not return this device to your dealer without first contacting customer support. Please do not discard the shipping carton in the trash. Please recycle whenever possible.

BOX CONTENTS

Omega Brackets (x2)
Power Cable

CUSTOMER SUPPORT

Contact **ELATION Service** for any product related service and support needs. Also visit forums.elationlighting.com with questions, comments or suggestions.

ELATION SERVICE USA - Monday - Friday 8:00am to 4:30pm PST
323-582-3322 | Fax 323-832-9142 | support@elationlighting.com

ELATION SERVICE EUROPE - Monday - Friday 08:30 to 17:00 CET
+31 45 546 85 63 | Fax +31 45 546 85 96 | support@elationlighting.eu

REPLACEMENT PARTS please visit parts.elationlighting.com

LIMITED WARRANTY (USA ONLY)

- A. Elation Professional hereby warrants, to the original purchaser, Elation Professional products to be free of manufacturing defects in material and workmanship for a period of two years (730 days), and Elation Professional product rechargeable batteries to be free of manufacturing defects in material and workmanship for a period of six months (180 days), from the original date of purchase. This warranty excludes discharge lamps and all product accessories. This warranty shall be valid only if the product is purchased within the United States of America, including possessions and territories. It is the owner's responsibility to establish the date and place of purchase by acceptable evidence, at the time service is sought.
- B. For warranty service, send the product only to the Elation Professional factory. All shipping charges must be pre-paid. If the requested repairs or service (including parts replacement) are within the terms of this warranty, Elation Professional will pay return shipping charges only to a designated point within the United States. If any product is sent, it must be shipped in its original package and packaging material. No accessories should be shipped with the product. If any accessories are shipped with the product, Elation Professional shall have no liability what-so-ever for loss and/or or damage to any such accessories, nor for the safe return thereof.
- C. This warranty is void if the product serial number and/or labels are altered or removed; if the product is modified in any manner which Elation Professional concludes, after inspection, affects the reliability of the product; if the product has been repaired or serviced by anyone other than the Elation Professional factory unless prior written authorization was issued to purchaser by Elation Professional; if the product is damaged because not properly maintained as set forth in the product instructions, guidelines and/or user manual.
- D. This is not a service contract, and this warranty does not include any maintenance, cleaning or periodic check-up. During the periods as specified above, Elation Professional will replace defective parts at its expense, and will absorb all expenses for warranty service and repair labor by reason of defects in material or workmanship. The sole responsibility of Elation Professional under this warranty shall be limited to the repair of the product, or replacement thereof, including parts, at the sole discretion of Elation Professional. All products covered by this warranty were manufactured after January 1, 1990, and bare identifying marks to that effect.
- E. Elation Professional reserves the right to make changes in design and/or performance improvements upon its products without any obligation to include these changes in any products theretofore manufactured.
- F. No warranty, whether expressed or implied, is given or made with respect to any accessory supplied with the products described above. Except to the extent prohibited by applicable law, all implied warranties made by Elation Professional in connection with this product, including warranties of merchantability or fitness, are limited in duration to the warranty periods set forth above. And no warranties, whether expressed or implied, including warranties of merchantability or fitness, shall apply to this product after said periods have expired. The consumer's and/or dealer's sole remedy shall be such repair or replacement as is expressly provided above; and under no circumstances shall Elation Professional be liable for any loss and/or damage, direct and/or consequential, arising out of the use of, and/or the inability to use, this product.
- G. This warranty is the only written warranty applicable to Elation Professional products and supersedes all prior warranties and written descriptions of warranty terms and conditions heretofore published.

WARRANTY RETURNS

All returned service items whether under warranty or not, must be freight pre-paid and accompany a return authorization (R.A.) number. The R.A. number must be clearly written on the outside of the return package. A brief description of the problem as well as the R.A. number must also be written down on a piece of paper and included in the shipping container. If the unit is under warranty, you must provide a copy of your proof of purchase invoice. Items returned without a R.A. number clearly marked on the outside of the package will be refused and returned at customer's expense. You may obtain a R.A. number by contacting customer support.

SAFETY GUIDELINES

This fixture is a sophisticated piece of electronic equipment. To guarantee a smooth operation, it is important to follow all instructions and guidelines in this manual. Elation Professional is not responsible for injury and/or damages resulting from the misuse of this fixture due to the disregard of the information printed in this manual. Only qualified and/or certified personnel should perform installation of this fixture and only the original rigging parts (omega brackets) included with this fixture should be used for installation. Any modifications to the fixture and/or the included mounting hardware will void the original manufactures warranty and increase the risk of damage and/or personal injury.



PROTECTION CLASS 1 - FIXTURE MUST BE PROPERLY GROUNDED



**THERE ARE NO USER SERVICEABLE PARTS INSIDE THIS UNIT.
DO NOT ATTEMPT ANY REPAIRS YOURSELF; DOING SO WILL VOID
YOUR MANUFACTURES WARRANTY. DAMAGES RESULTING FROM
MODIFICATIONS TO THIS FIXTURE AND/OR THE DISREGARD OF
SAFETY INSTRUCTIONS AND GUIDELINES IN THIS MANUAL VOID THE
MANUFACTURES WARRANTY AND ARE NOT SUBJECT TO ANY
WARRANTY CLAIMS AND/OR REPAIRS.**



**DO NOT PLUG FIXTURE INTO A DIMMER PACK!
NEVER OPEN THIS FIXTURE WHILE IN USE!
UNPLUG POWER BEFORE SERVICING FIXTURE!
NEVER TOUCH FIXTURE DURING OPERATION, AS IT MAY BE HOT!
KEEP FLAMMABLE MATERIALS AWAY FROM FIXTURE!**



**NEVER LOOK DIRECTLY INTO THE LIGHT SOURCE!
RETINA INJURY RISK - MAY INDUCE BLINDNESS!
SENSITIVE PERSONS MAY SUFFER AN EPILEPTIC SHOCK!**



**INDOOR / DRY LOCATIONS USE ONLY!
DO NOT EXPOSE FIXTURE TO RAIN AND MOISTURE!**



**MINIMUM DISTANCE TO OBJECTS/SURFACES
MUST BE 13.1 FEET (4 METERS)
MAXIMUM TEMP OF EXTERNAL SURFACE 185° F (85°C)
MINIMUM DISTANCE OF INFLAMMABLE MATERIALS
FROM THE SURFACE 1.6 FEET (0.5 METER)**

SAFETY GUIDELINES

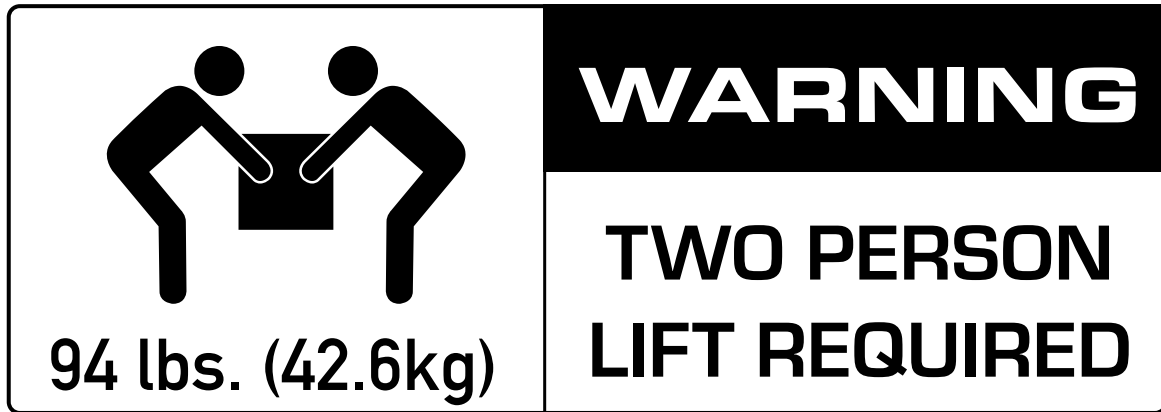

⚠ CAUTION

**HIGH
INTENSITY
ULTRAVIOLET
LIGHT**

AVOID DIRECT EYE & SKIN EXPOSURE.
WEAR PROPER EYE & SKIN PROTECTION.
SEE MANUAL FOR SAFETY INSTRUCTIONS.



RISK GROUP 3 - RISK OF EXPOSURE TO ULTRAVIOLET UV RADIATION! FIXTURE EMITS HIGH INTENSITY WAVELENGTH OF ULTRAVIOLET UV LIGHT FROM THE UV COLOR FILTER. WEAR PROPER EYE AND SKIN PROTECTION. AVOID PROLONGED PERIODS OF EXPOSURE TO UV COLOR FILTER. AVOID WEARING WHITE COLOR CLOTHING AND/OR USING UV PAINTS ON SKIN. AVOID DIRECT EYE AND/OR SKIN EXPOSURE AT DISTANCES LESS THAN 11 feet (3.3m). DO NOT OPERATE FIXTURE WITH DAMAGED/MISSING EXTERNAL COVERS. DO NOT LOOK DIRECTLY

INTO THE UV LIGHT AND/OR VIEW UV LIGHT DIRECTLY WITH OPTICAL INSTRUMENTS THAT MAY CONCENTRATE THE LIGHT/RADIATION OUTPUT. INDIVIDUALS SUFFERING FROM A RANGE OF EYE CONDITIONS, SUNLIGHT EXPOSURE DIS-ORDERS, OR INDIVIDUALS USING PHOTSENSITIVE MEDICATION, MAY RECEIVE DISCOMFORT IF EXPOSED TO THE ULTRAVIOLET UV LIGHT EMITTED FROM THE UV LED.

DO NOT TOUCH the fixture housing during operation. Turn OFF the power and allow approximately 15 minutes for the fixture to cool down before serving.

DO NOT shake fixture, avoid brute force when installing and/or operating fixture.

DO NOT operate fixture if the power cord is frayed, crimped, damaged and/or if any of the power cord connectors are damaged and do not insert into the fixture securely with ease. **NEVER** force a power cord connector into the fixture. If the power cord or any of its connectors are damaged, replace it immediately with a new one of similar power rating.

DO NOT block any air ventilation slots.

All fan and air inlets must remain clean and never blocked.

Allow approx. 6" (15cm) between fixture and other devices or a wall for proper cooling.

Always disconnect fixture from main power source before performing any type of service and/or cleaning procedure. Only handle the power cord by the plug end, never pull out the plug by tugging the wire portion of the cord.

During the initial operation of this fixture, a light smoke or smell may emit from the interior of the fixture. This is a normal process and is caused by excess paint in the interior of the casing burning off from the heat associated with the lamp and will decrease gradually over time.

Consistent operational breaks will ensure fixture will function properly for many years.

ONLY use the original packaging and materials to transport the fixture in for service.

FIXTURE TRANSPORT AND HANDLING

The Artiste Monet is a large format fixture that contains delicate optics and glass filters. While this product was carefully designed to be roadworthy, it must be handled carefully during transportation. Before transport, ensure that the color flags inside the unit are placed in an OPEN position. For superior impact protection, the fixture is shipped in a custom fitted high-density Foam Inlay (FIL). This FIL must be used inside the road-cases for transportation.

DO NOT Tip the case over, and avoid all shocks and rough handling, especially “tipping”, the practice of tipping the fixture-case over to its side and onto a hard surface. The case must ride on its wheels so that the fixture-head remains horizontal during transportation.

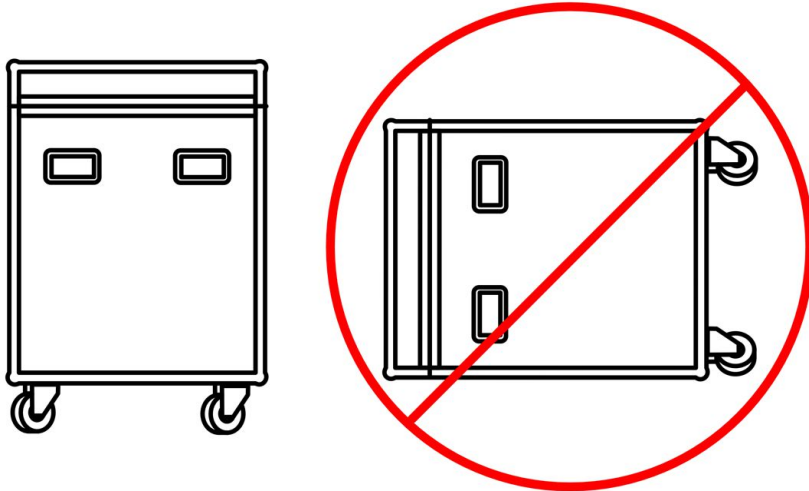

MAINTENANCE GUIDELINES



DISCONNECT POWER BEFORE PERFORMING ANY MAINTENANCE!

CLEANING

Frequent cleaning is recommended to insure proper function, optimized light output, and an extended life. The frequency of cleaning depends on the environment in which the fixture operates: damp, smoky or particularly dirty environments can cause greater accumulation of dirt on the fixture’s optics. Clean the external lens surface at least every 20 days with a soft cloth to avoid dirt/debris accumulation.

NEVER use alcohol, solvents, or ammonia-based cleaners.

MAINTENANCE

Regular inspections are recommended to insure proper function and extended life. There are no user serviceable parts inside this fixture, please refer all other service issues to an authorized Elation service technician. Should you need any spare parts, please order genuine parts from your local Elation dealer. Please refer to the following points during routine inspections:

- A detailed electric check by an approved electrical engineer every three months, to make sure the circuit contacts are in good condition and prevent overheating.
- Be sure all screws and fasteners are securely tightened at all times. Loose screws may fall out during normal operation resulting in damage or injury as larger parts could fall. Check for any deformations on the housing, color lenses, rigging hardware and rigging points (ceiling, suspension, trussing). Deformations in the housing could allow for dust to enter into the fixture. Damaged rigging points or unsecured rigging could cause the fixture to fall and seriously injure a person(s).
- Electric power supply cables must not show any damage, material fatigue or sediments. **NEVER** remove the ground prong from the power cable.

FIXTURE OVERTURE

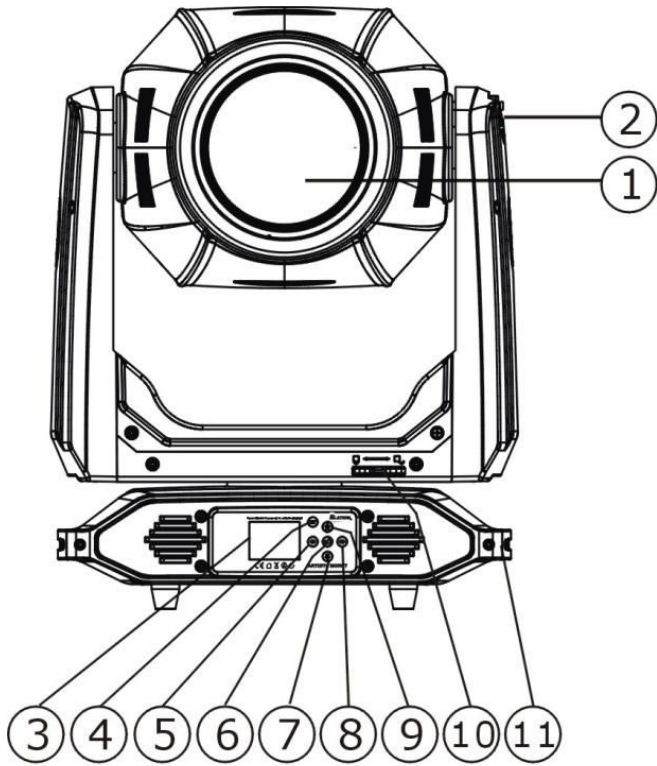

1. Lens
2. Tilt Lock
3. System Menu Display
4. MODE/ESC Button
5. LEFT Button
6. ENTER Button
7. DOWN Button
8. RIGHT Button
9. UP Button
10. Pan Lock
11. Carrying Handle(s)

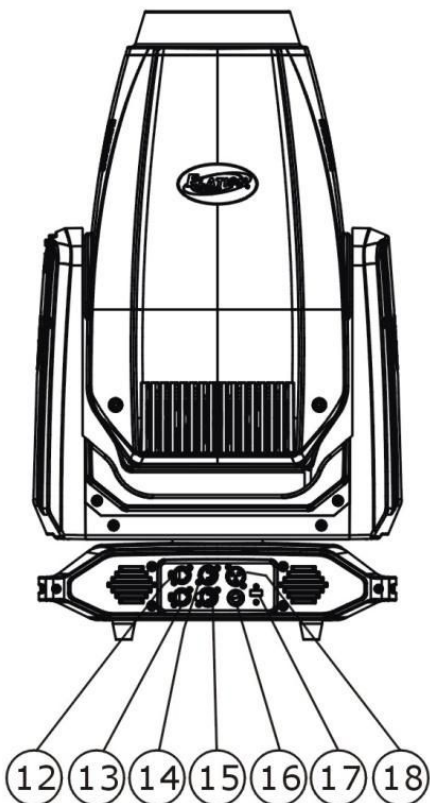

12. RJ45 Input
13. RJ45 Output
14. 5pin DMX Input
15. 5pin DMX Output
16. Fuse
17. Fuse
18. Power Input

COLORS, GOBOS, ANIMATION

COLOR FLAGS



CYAN MAGENTA YELLOW C.T.O. RED GREEN BLUE

COLOR WHEEL



RED GREEN U V HIGH CRI ORANGE BLUE

INTERCHANGEABLE-ROTATING GLASS GOBO WHEEL 1



STATIC-FIXED GLASS GOBO WHEEL 2

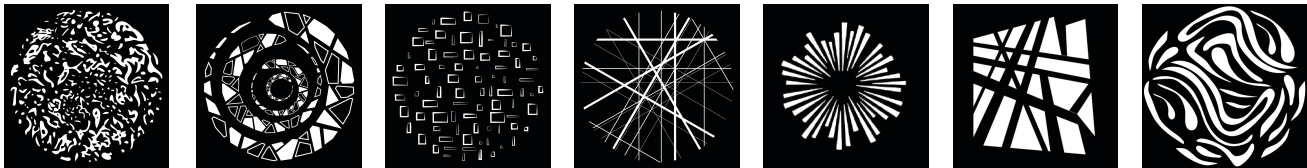

ANIMATION WHEEL

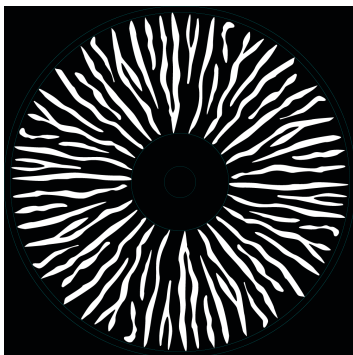

SPECTRACOLOR GUIDE

The Monet's innovative SpectraColor system combines the established and well known CMY / CTO controls with three Pure RGB flags that are seamlessly adjustable. These flags greatly enhance the possible color range of the Monet for some truly outstanding colors that can be difficult to achieve with only CMY controls.

It is recommended to familiarize yourself with this unique color system, to fully unlock the creative potential of the SpectraColor array.

Cyan, Magenta and Yellow saturation chosen for a wide color range and are aligned with other colors in the Artiste range. CMY is a subtractive color mix which removes certain colors from the light to create the desired color. Flags can be combined in any saturation to create a wide range of mixed colors.

RGB are "pure" color points chosen for best saturation. These are also subtractive, e.g. adding the Red flag will remove all other wavelengths. While it is possible to overlap the RGB colors it will eventually black out the fixture as all colors are essentially reducing towards no output.

On consoles they should be shown as Pure Red, Pure Green and Pure Blue. This is done so console colors pickers do not interact with the RGB flags. All color flags must default to 0% in the console profiles.

Mixing CMY colors is identical to many other fixtures in the market. CMY colors can of course combine with the CTO to create a warmer array of colors. Overall the behavior of the CMY system should feel familiar and with the high intensity of the Monet all colors are brilliant and powerful.

The CTO filter is designed to adjust the Monet from its native color temperature of 6500K to 2700K. Full CTO in combination with Cyan Magenta or Yellow allow for a warmer color palette. For example, Yellow shifts from a slightly greenish tone to a warm amber yellow. Utilizing the adjustable CTO with the CMY system greatly enhances the color range of the Monet.

Using Pure Colors

Pure Red, Green or Blue are ideal colors to create subtle hues to saturated colors. Mixing a slight blue shifts the Monet from White over CTB over light to medium purples until it reaches a rich Medium Blue. Using Green allows teals and green tints similar to fluorescent fixtures until it transitions into a bright medium green. These color tones makes the Monet an ideal tool for theater and opera designers as the SpectraColor system allows to replicate many color spectrums associated with unique light sources like metal halide, sodium vapor or fluorescent tubes out of one fixture.

Creating Color Mixes Using SpectraColor

CMY and RGB flags can be combined as well to widen the color gamut of the CMY mix. Start with a slight to saturated CMY color, then add a little of Red, Green or Blue to change the hue. Never use RGB together, only one of those colors at a time will be useful. Otherwise the fixture will only get darker as overlapping RGB acts like a dim to black.

Perceived Color Brightness

Please be aware that due to the very high intensity of the Monet the CMY colors may not look fully saturated, especially when placed next to a lower intensity fixture. This is misleading as your eye cannot handle the high intensity well and colors that are in fact identical may appear different to your eye. To confirm simply dim down the Monet to match the output level of a comparison fixture. You should find color appearing more saturated, even though nothing has changed on the color itself. Reducing the output helps your eye to see the color better.

ADDED WITH SOFTWARE UPDATE VERSION $\geq 1.3.4$ and $\geq 1.4.1$

FAN MODES and LOW NOISE OPERATION

The Artiste Monet is a high-performance fixture suited for multiple applications. For noise critical environments such as Theater, Opera or Orchestra Halls, it offers various fan operation modes which remove any distraction for the audience and performers. Fan Modes can be changed remotely via the DMX control channel, allowing the fixture to offer high output or whisper silent operation at a moment's notice. All Fan Modes smoothly transition over a brief time period, preventing unwanted attraction to the fixture.

Mode	dbA at 1m LED off	dbA at 1m Dimmer 100%
Fan Control - Auto (Default)	39	46
Fan Control - Low	38	40
Fan Control - High	50	59
Low Noise – Studio	34	37
Low Noise – Mute	32	33

Auto (Default) – Fans only run at the speeds needed to keep the LED engine within a safe temperature range and ensures optimal performance of the fixture. They will turn off if possible, for example when the fixture is dimmed to a low intensity. Fans sense the ambient and fixture temperature and will at all times try to keep noise levels at a minimum. The fixture output will only reduce when the LED engine cannot be cooled down to its safe operating range due to high ambient temperature.

NOTE: Recommended for daily operation.

Low – Fan speeds are reduced throughout for a lower noise profile. The fixture output is also reduced to approximately 80%. This mode should be sufficient for most uses where lower noise is required.

High – Fan speeds are increased throughout for the most efficient cooling of the fixture. This mode will increase wear on the fans and should only be utilized in exceptional circumstances. Fans will always run, even if the fixture is dimmed down. Fixture output is kept at 100% unless the LED engine temperature reaches an unsafe temperature at which point the fixture will reduce power carefully to ensure continued safe operation. This mode is only required in very high ambient temperatures when automatic fan speed adjustments are not desired.

Low Noise Modes

For very critical noise environments, the fixture offers two additional Low Noise Modes for silent operation. The fixture output will be reduced, however due to the extremely high luminous flux the fixture still offers outstanding performance. In Low Noise Modes all parameters of the fixture operate quieter with reduced fan speeds.

Studio – Almost all fixture fans are turned off and only run when absolutely necessary. The fixture LED power output is reduced to 50%.

Mute – All but one fixture fan is turned off for whisper quiet operation. The fixture LED power output is reduced to 25%.

CUSTOM GOBOS

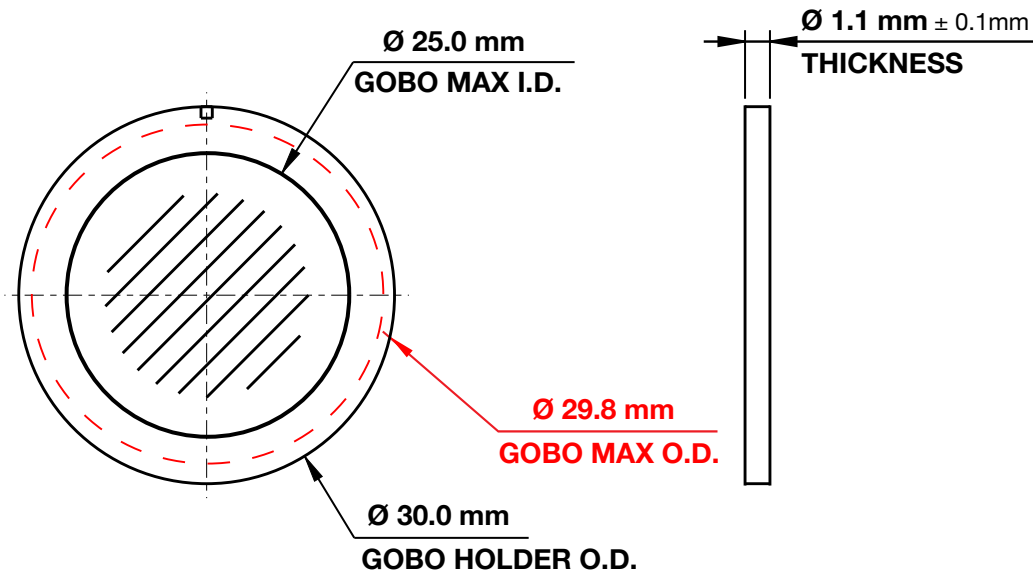

ROTATING & STATIC GLASS GOBOS - WHEEL 1 + 2	
Gobo O.D. (Max. Outer Diameter)	φ29.8mm
Gobo I.D. (Max. Image Diameter)	φ25.0mm
Gobo Holder Diameter	φ30.0mm
Gobo Thickness	1.1mm±0.1mm
Gobo Material	High Temp Glass (Minimum 600C°)

***** IMPORTANT NOTICE REGARDING CUSTOM GOBOS *****

Due to the high temperature optical system, special material as listed above is required for custom gobos. Due to varying manufacturing processes and tolerances, it is highly recommended to provide a gobo sample and holder from the fixture to the custom gobo vendor for accurate sizing. Extended testing of custom gobo designs is highly recommended prior to use. Contact ELATION SERVICE for further information.

ELATION SERVICE USA - Monday - Friday 8:00am to 4:30pm PST

323-582-3322 | Fax 323-832-9142 | support@elationlighting.com

ELATION SERVICE EUROPE - Monday - Friday 08:30 to 17:00 CET

+31 45 546 85 63 | Fax +31 45 546 85 96 | support@elationlighting.eu

GOBO INSTALLATION



1. Before removing covers, place fixture on a stable flat surface in an **INDOOR DUST FREE** location. Ensure moving head is locked into a neutral upright position with both PAN and TILT locks engaged.



2. Loosen (2x) ¼-turn Phillips-head screws on top and bottom covers. (screws integrated into covers - cannot be removed)

Gently lift covers and unclip safety cables to remove both completely from the fixture.

GOBO INSTALLATION

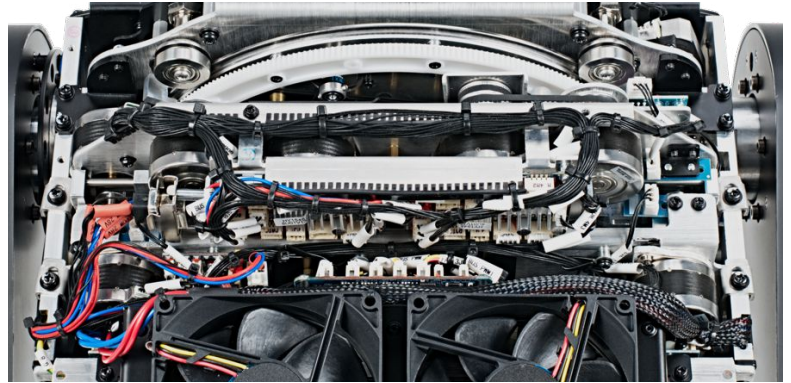
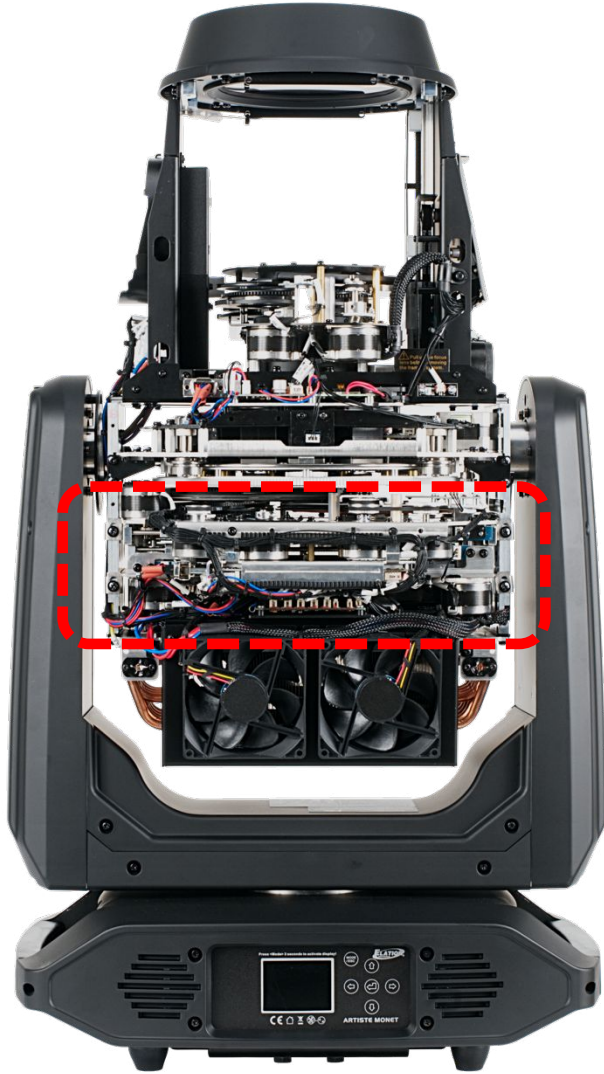

3. The GOBO Wheel module is secured to the fixture frame rail with (4x) sliding slotted brackets. To remove the module, loosen the (4x) Philips-head screws just enough (do not remove them) to allow the slotted brackets to slide down.

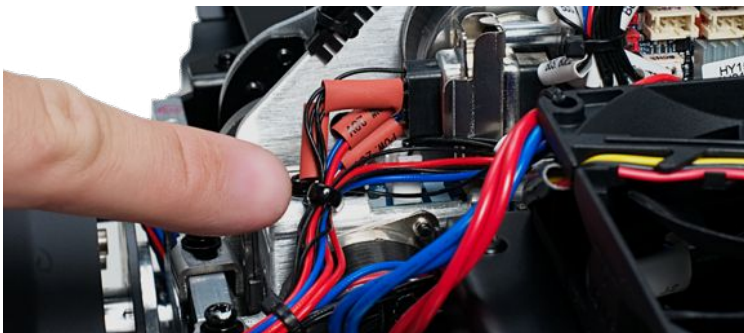

4. The wire harnesses connected to the GOBO Wheel module are secured with a flexible metal stay. Unbend this metal stay to ungroup the wires connected to the GOBO Wheel module.

GOBO INSTALLATION

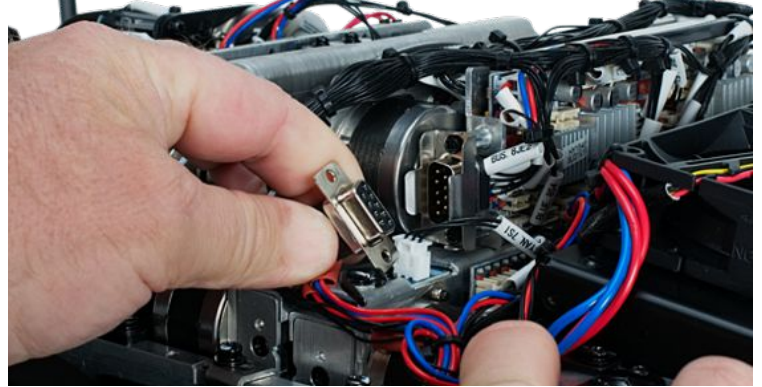
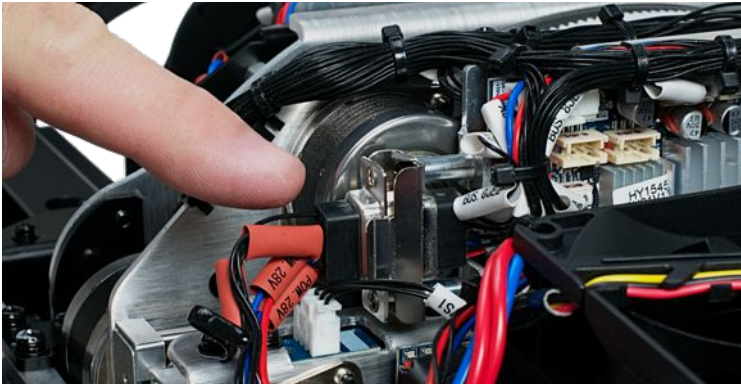

5. Locate the 9-pin connector and carefully unplug it from its socket. **DO NOT USE FORCE TO REMOVE!**

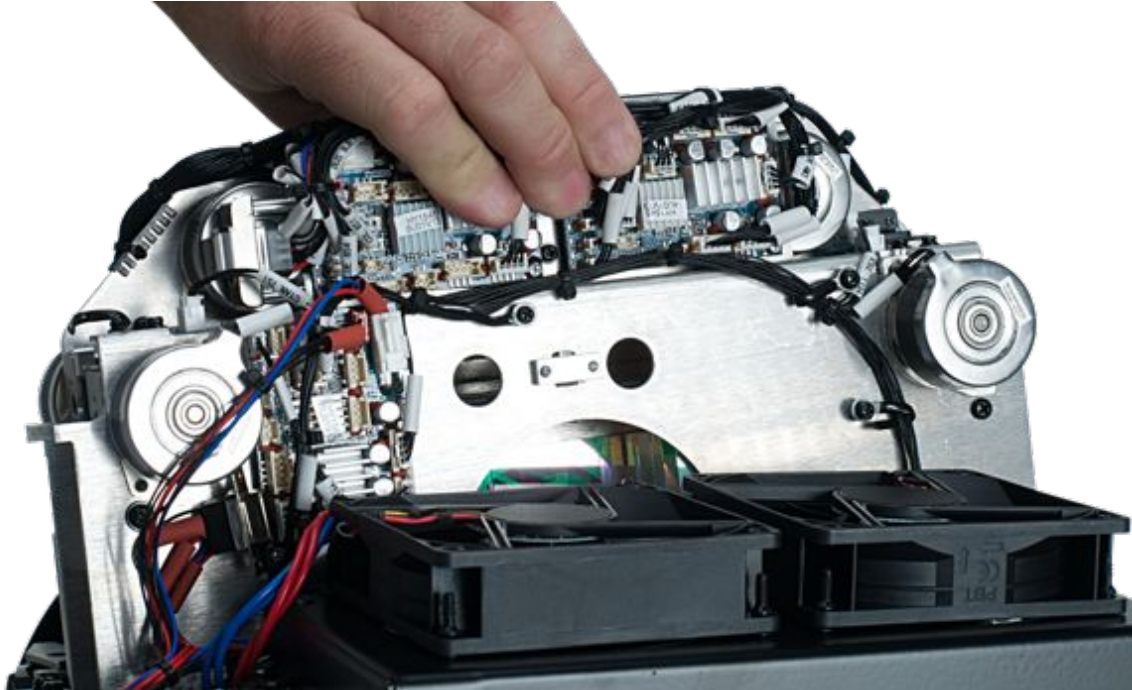

6. Carefully grip the GOBO Wheel module and slid it out just enough to reveal two more wire connectors.

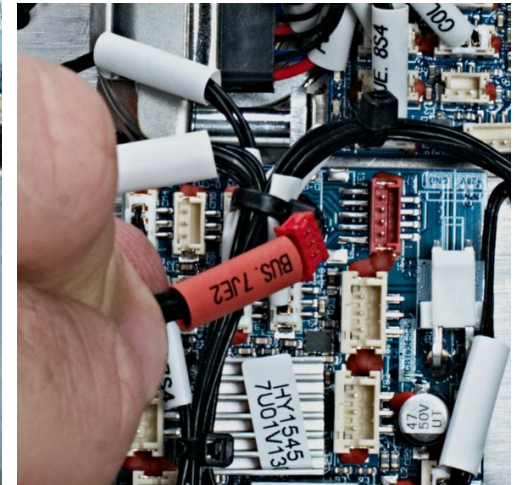
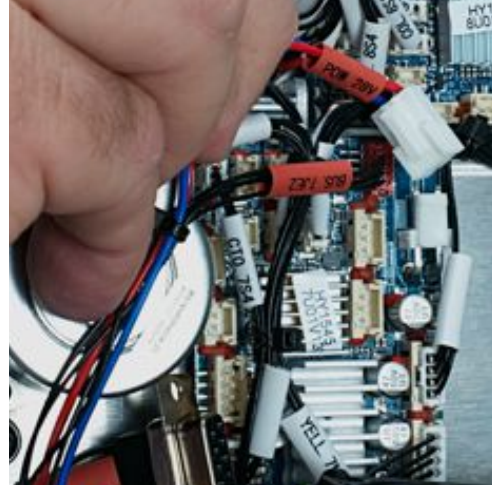
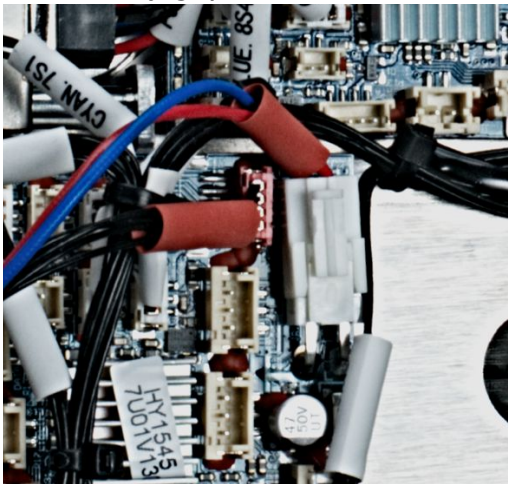

7. Unplug the 2-pin and 4-pin connectors that are attached to the module.

GOBO INSTALLATION

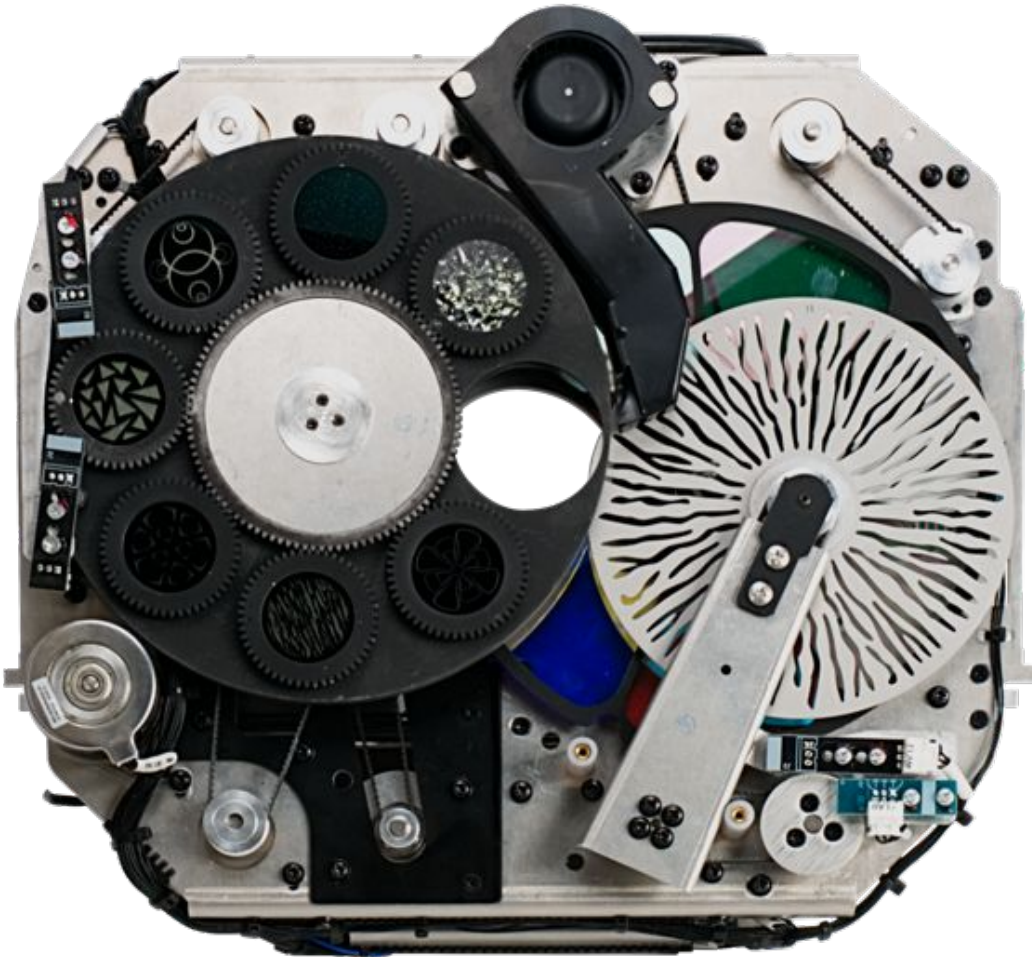

8. Slide the GOBO Wheel module completely out and away from the fixture. Carefully place the module on a stable flat surface in an **INDOOR DUST FREE** location.



9. REPLACING A ROTATING GOBO

Locate the specific Rotating GOBO to replace. Carefully grip the GOBO using your thumb and index finger, gently lifting it slightly up and then pulling it out and away until it fully clears from the GOBO Wheel.

GOBO INSTALLATION



10. Locate the tab of the retaining spring. Using a precision pick (or similar tool), carefully press the retaining spring inward to relieve the tension. Remove the retaining spring and carefully separate the GOBO from the GOBO Holder. Lastly, remove the flat washer attached to the removed GOBO and attach it to the desired replacement GOBO. Install the replacement Rotating GOBO following the steps above in reverse order.



CAUTION: TAKE CARE NOT TO SCRATCH GOBO OR GOBO HOLDER!

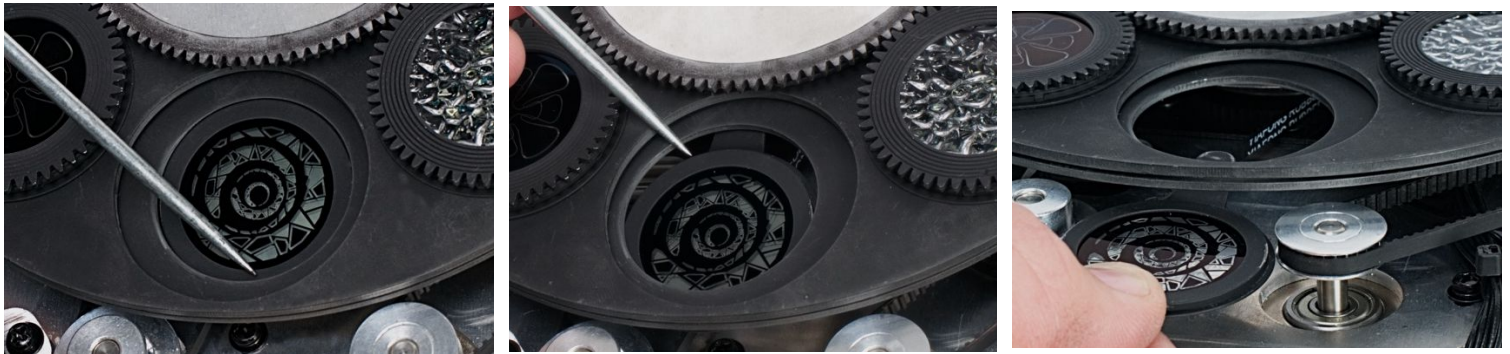

11. REPLACING A STATIC GOBO

Rotate the Static GOBO Wheel until the desired GOBO is visible through the OPEN slot in the Rotating GOBO Wheel. Using a precision pick (or similar tool), carefully press the Static GOBO Holder down slightly then using your thumb and index finger, gently pull it out and away until it fully clears from the GOBO Wheel.

12. Locate the tab of the retaining spring. Using a precision pick (or similar tool), carefully press the retaining spring inward to relieve the tension. Remove the retaining spring and carefully separate the GOBO from the GOBO Holder. Lastly, remove the flat washer attached to the removed GOBO and attach it to the desired replacement GOBO. Install the replacement Static GOBO following the steps above in reverse order.

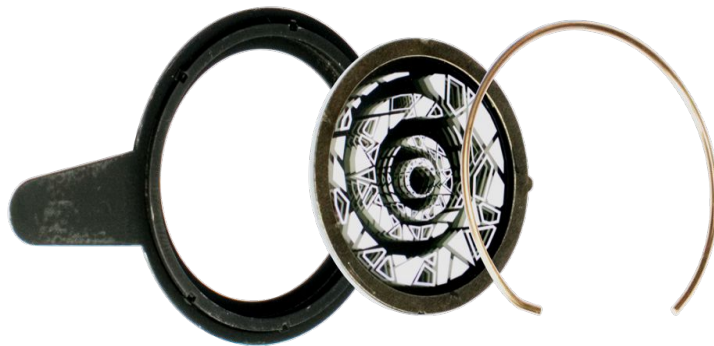

CAUTION: TAKE CARE NOT TO SCRATCH GOBO OR GOBO HOLDER!

INSTALLATION GUIDELINES



FLAMMABLE MATERIAL WARNING

Keep fixture minimum 5.0 feet (1.5m) away from flammable materials and/or pyrotechnics.



ELECTRICAL CONNECTIONS

A qualified electrician should be used for all electrical connections and/or installations.



USE CAUTION WHEN POWER LINKING OTHER MODEL FIXTURES AS THE POWER CONSUMPTION OF OTHER MODEL FIXTURES MAY EXCEED THE MAX POWER OUTPUT ON THIS FIXTURE. CHECK SILK SCREEN FOR AMX AMPS.



**MINIMUM DISTANCE TO OBJECTS/SURFACES
MUST BE 13.1 FEET (4 METERS)**



**MINIMUM DISTANCE OF INFLAMMABLE MATERIALS
FROM THE SURFACE 1.6 FEET (0.5 METER)**



MAXIMUM TEMPERATURE OF EXTERNAL SURFACE 185° F (85°C)



DO NOT INSTALL THE FIXTURE IF YOU ARE NOT QUALIFIED TO DO SO!

Fixture **MUST** be installed following all local, national, and country commercial electrical and construction codes and regulations.

Before rigging/mounting a single fixture or multiple fixtures to any metal truss/structure or placing the fixture(s) on any surface, a professional equipment installer **MUST** be consulted to determine if the metal truss/structure or surface is properly certified to safely hold the combined weight of the fixture(s), clamps, cables, and accessories.

Overhead rigging requires extensive experience, including amongst others calculating working load limits, installation material being used, and periodic safety inspection of all installation material and the fixture. If you lack these qualifications, do not attempt the installation yourself. Improper installation can result in bodily injury.

Fixture ambient operating temperature range is **14° to 113°F. (-10° to 45°C)**

Do not use the fixture under or above this temperature.

Fixture(s) should be installed in areas outside walking paths, seating areas, or away from areas where unauthorized personnel might reach the fixture by hand.

NEVER stand directly below the fixture(s) when rigging, removing or servicing.

Overhead fixture installation must always be secured with a secondary safety attachment, such as an appropriately rated safety cable.

Allow approximately 15 minutes for the fixture to cool down before serving.

INSTALLATION GUIDELINES

OMEGA BRACKETS INSTALLATION

Insert the Omega Brackets into the matching holes on the bottom of the fixture. Secure the Omega Brackets to the fixture by turning each quick-lock fastener ¼ turn clockwise; making sure the fastener is completely locked. Omega Brackets can be installed into the fixture base as illustrated below.



CLAMP INSTALLATION

When mounting fixture to truss, be sure to secure an appropriately rated professional grade rigging clamp to the included **Omega Brackets** using an M10 screw fitted through the center hole of the **Omega Brackets**. The fixture provides a built-in rigging points for a **SAFETY CABLE**. Be sure to only use one of the designated rigging points for the safety cable and never secure a safety cable to a carrying handle.

RIGGING

Overhead rigging requires extensive experience, including amongst others calculating working load limits, installation material being used, and periodic safety inspection of all installation material and the fixture. If you lack these qualifications, do not attempt the installation yourself. Improper installation can result in bodily injury.



ALWAYS ATTACH AN APPROPRIATELY RATED SAFETY CABLE (NOT INCLUDED) THAT MEETS ALL LOCAL, NATIONAL, AND COUNTRY CODES AND REGULATIONS WHENEVER INSTALLING FIXTURE IN A SUSPENDED ENVIRONMENT!

ART-NET | sACN CONNECTION

When connecting fixture to a network switch to control multiple devices, a **Gigabit Ethernet Switch** that supports **IGMP (Internet Group Management Protocol)** is required. Using a **Gigabit Ethernet Switch** that does not support **IGMP** can cause erratic behavior of all connected devices to the switch. Click link below for more information about IGMP.

https://en.wikipedia.org/wiki/Internet_Group_Management_Protocol

INSTALLATION GUIDELINES

POTENTIAL INTERNAL FIXTURE DAMAGE FROM EXTERNAL SOURCES OF LIGHT BEAMS

External sources of light beams from direct sunlight, lighting moving head fixtures, and lasers, which are focused directly on the exterior housing and/or penetrate the front lens opening of ELATION lighting fixtures, can cause severe internal damage including burning to optics, dichroic color filters, glass and metal gobos, prisms, animation wheels, frost filters, iris, shutters, motors, belts, wiring, discharge lamps, and LEDs.

This issue is not specific only to ELATION lighting fixtures, it is a common issue with lighting fixtures from all manufacturers. Although there is no true way to fully prevent this issue from happening, the guidelines below can prevent any potential damage from occurring if followed. Contact ELATION Service for more details.

DO NOT EXPOSE THE FIXTURE AND/OR FRONT LENS OPENING TO LIGHT BEAMS FROM DIRECT SUNLIGHT, OTHER LIGHTING MOVING HEAD FIXTURES, AND LASERS WHILE UNPACKING, INSTALLATION, USE, AND EXTENDED IDLE TIMES OUTDOORS. DO NOT FOCUS A LIGHT BEAM FROM ONE LIGHTING FIXTURE DIRECTLY TOWARDS ANOTHER.

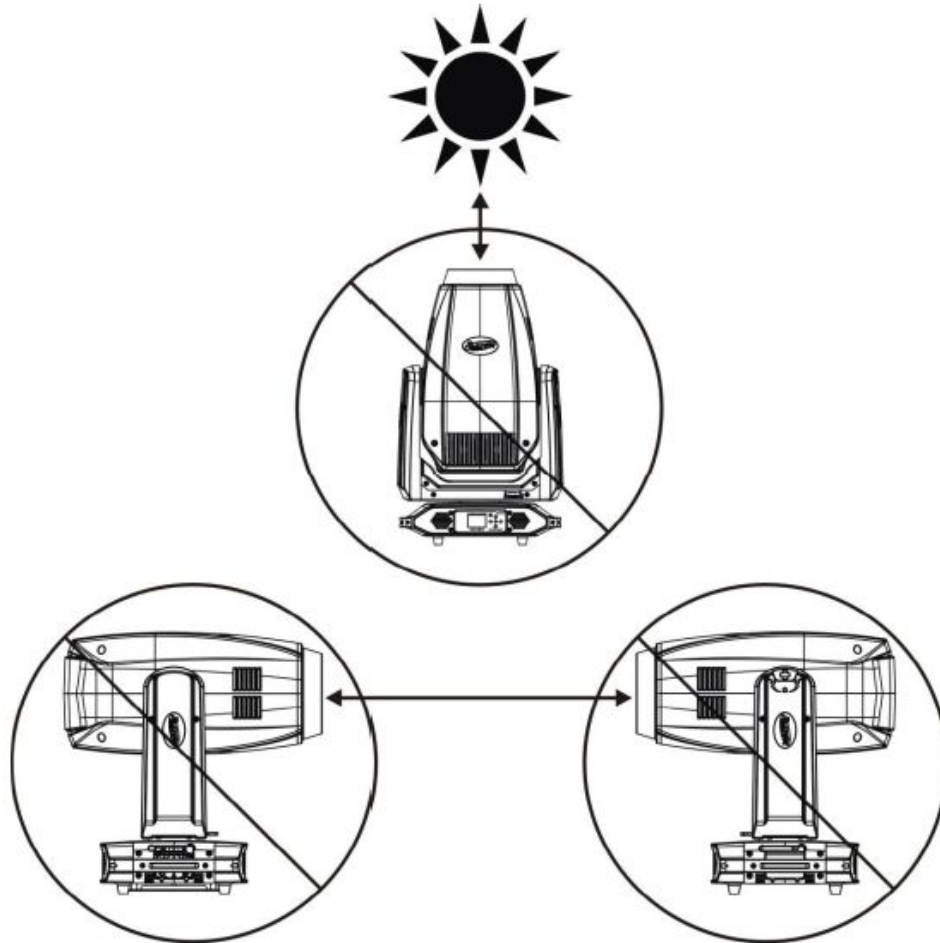

SUN PROTECTION MODE

The fixture incorporates an automatic protection from harmful sunlight, which can damage a fixture's internal components from extended exposure. Fixtures use an internal sensor to determine their physical orientation, then reorient the fixture towards the ground to prevent sunlight from entering the lens.

This automatic feature only works when the fixture is powered. If the fixture is unpowered during setup, it is necessary to manually reorient the lenses away from the sun and aim them towards the ground. Even a few minutes of sun exposure can cause damage inside the fixture.

The Sun Protection setting is accessed via the "No DMX Status" menu.

The automatic sun protection positioning is activated under the following conditions:

1. Power on without DMX signal: the fixture always starts in sun protection mode.
2. No DMX Status "Sun Protection": the fixture enters sun protection mode after approximately 3 minutes.
3. Remote DMX control: the sun protection position can be **temporarily** activated from the lighting console without the need to create a custom position preset. The fixture senses the correct ground orientation. This means that fixtures already facing the ground may not move their heads.

Hold "Sun Protect Position" for 3s to set the fixture to the sun protection position.

Sun protection status displays as "**Sun Protection: Active**".

The sun protection position deactivates under the following conditions:

1. Connect DMX signal.
2. Remote DMX control: Hold "Sun Protection Off" for 3s.

To avoid harsh or jarring movements, the sun protection position always uses a 5-second fade time when it is activated or deactivated.

HIBERNATION MODE

To reduce wear on the fixture and its components, this mode disables motors and most electronics. Set the hibernation mode countdown time in the Display Menu: "Status Settings / Personality / Hibernation". Hibernation can be fully disabled.

The hibernation mode activates under the following conditions:

1. Loss of DMX: the fixture enters hibernation after the timeout expires. Default is 15 minutes.
2. Remote DMX control: Hold "Hibernate Fixture" for 3s

The hibernation mode deactivates under the following conditions:

1. Connect DMX Signal
2. Remote DMX control: Hold "Hibernate Off" for 3s

The fixture will perform a full calibration cycle, then assume the current DMX status.

Please note that the Hibernation does not change the PT position of the fixtures, allowing the user to set the desired position and then issue the Hibernate command.

To ensure the fixture is protected from harmful sunrays it is recommended to either leave the "No DMX Status" in "Sun Protection" (so the fixture is already in the correct position after 3 minutes of DMX loss) or set the fixture to a safe Tilt position manually first before hibernation.

Burn and heat damage to the fixture's interior components due to external light sources (sun or other fixtures shining into the lens) is never covered under the manufacturer's warranty.

REMOTE DEVICE MANAGEMENT (RDM)

NOTE: For RDM to work properly, RDM enabled equipment must be used throughout the entire system, including DMX data splitters and wireless systems.

Remote Device Management (RDM) is a protocol that sits on top of the DMX512 data standard for lighting, allowing the DMX systems of the fixtures to be modified and monitored remotely. This protocol is ideal for instances in which a unit is installed in a location that is not easily accessible.

With RDM, the DMX512 system becomes bi-directional, allowing a compatible RDM enabled controller to send out a signal to devices on the wire, as well as allowing the fixture to respond (known as a GET command). The controller can then use its SET command to modify settings that would typically have to be changed or viewed directly via the unit's display screen, such as the DMX Address, DMX Channel Mode, and Temperature Sensors.

RDM Code	Device ID	Device Model ID	Personality ID
0X609	OPEN	1545	OPEN

Please be aware that not all RDM devices support all RDM features, and therefore **it is important to check beforehand to ensure that the equipment that you are considering includes all the features that you require.**

The following parameters are accessible in RDM on this device:

LED Fixture
Sensor Definition
Sensor Value
Device Model Description
Manufacturer Label
Device Label
DMX Personality
DMX Personality Description
Device Hours
Pan Invert
Tilt Invert
Display Invert

SYSTEM MENU

The fixture includes an easy to navigate system menu. The control panel (see image below) located on the front of the fixture, provides access to the main system menu and is where all necessary system adjustments are made to the fixture. During normal operation, pressing **MODE/ESC** button once will access the fixture's main menu. Once in the main menu you can navigate through the different functions and access the sub-menus with the **UP, DOWN, RIGHT,** and **LEFT** buttons. Once you reach a field that requires adjusting, press the **ENTER** button to activate that field and use the **UP** and **DOWN** buttons to adjust the field. Pressing the **ENTER** button once more will confirm your setting. You may exit the main menu at any time without making any adjustments by pressing the **MODE/ESC** button.

To access the LCD Menu Control Display via the internal battery, press and hold the **MODE/ESC** button for 3 seconds. The LCD Menu Control Display will shut **OFF** automatically about 1 minute from the last button press.

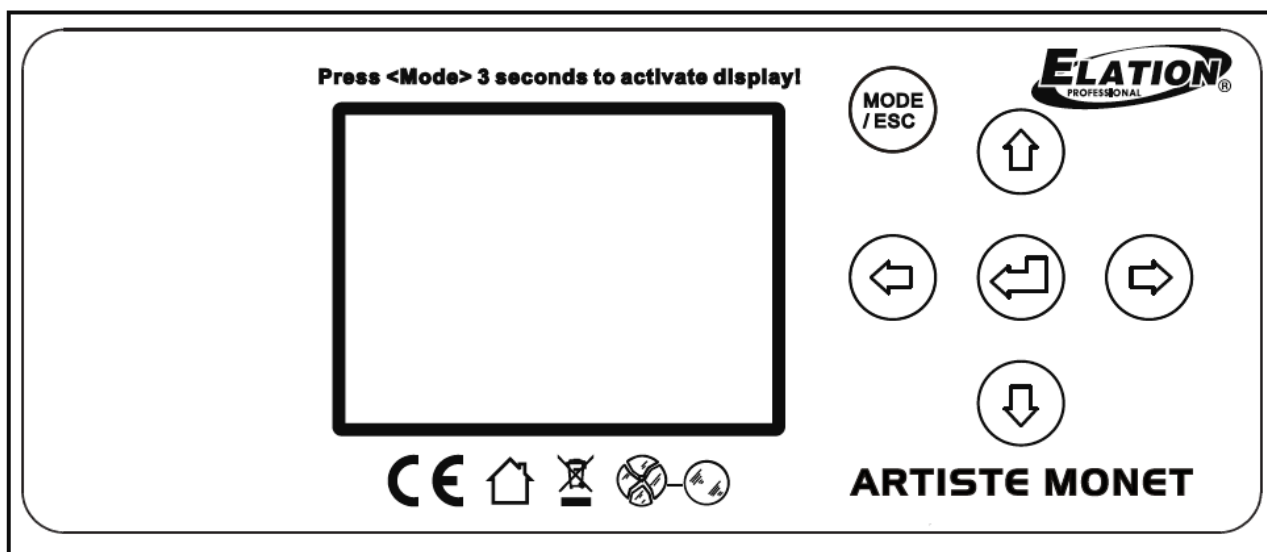

AN ELATION E-LOADER III CAN BE USED TO UPDATE THE FIXTURE TO THE LATEST SOFTWARE. TO ORDER THIS DEVICE, PLEASE CONTACT ELATION SUPPORT FOR FURTHER DETAILS.

**ELATION SERVICE USA - Monday - Friday 8:00am to 4:30pm PST
323-582-3322 | Fax 323-832-9142 | support@elationlighting.com**

**ELATION SERVICE EUROPE - Monday - Friday 08:30 to 17:00 CET
+31 45 546 85 63 | Fax +31 45 546 85 96 | support@elationlighting.eu**

ELATION ARTISTE MONET™ - S Y S T E M M E N U

Supports Software Versions: ≥ 1.3.3

Features subject to change without notice. *Rotation direction (Clockwise/Counterclockwise) and control of effects depends on head orientation and Pan/Tilt settings.

MAIN MENU	SUB MENU	OPTIONS / VALUES (Default Settings in BOLD)		DESCRIPTION	
FUNCTION	Set Dmx Address	A001~AXXX		DMX Address Setting	
	Dmx Value	ALL.....		DMX Value Display	
	Secondary Mode	Secondary1, Secondary2, Secondary3		Secondary Setting	
	Auto Program	Primary / Alone		Auto Program	
INFORMATION	Time Information	Current Time	XXXX (Hours)	Fixture Run Time From Power ON	
		Total Run Time	XXXX (Hours)	Fixture Total Run Time	
		Last Run Time	XXXX (Hours)	Fixture Last Run Time	
		LastRun Password	Password= 038	(PSWD Required)	
		Clear Last Run	ON / OFF	Clear Fixture Last Run Time	
	Temperature Info	LED Temperature	XXX C° / F °	Temperature of LED Engine	
		Head Temperature	XXX C° / F °	Temperature in Fixture Head	
		Base Temperature	XXX C° / F °	Temperature in Fixture Base	
	Ethernet IP	000 . 000 . 000 . 000	000 . 000 . 000 . 000	Displays Fixture Ethernet Address	
	Fan Info	HeadFan: xxxx RPM		Displays Fan Info	
Software Version	1U01: ~	≥V1.3.3	Software Version		
Error Info	Error Record 1 ~ Error Record 10		Fixture Last 10 Error Codes		
PERSONALITY	Status Settings	Address via DMX	ON/OFF	Address Via DMX	
		No DMX Status	Close / Hold / Auto	Fixture State When NO DMX Signal	
		Pan Reverse	ON/OFF	Pan Reverse Movement	
		Tilt Reverse	ON/OFF	Tilt Reverse Movement	
		Pan Degree	630/540	Pan Degree Select	
		Feedback	ON/OFF	Movement Feedback	
		Movement Speed	Normal / Slow	Movement Speed	
		P/T Brake Mode	Smooth/ Fast	Pan/Tilt Brake Mode	
	Hibernation	OFF, 01M~99M, 15M	Stand By Mode		
	Service Setting	Password	Password= 050		Service Password
		Clear Err. Info	ON/OFF		Clear Error Info (PSWD Required)
		RDM UID	22A6xxxxxxx		RDM PID Code (PSWD Required)
		DFLT Pow. EflyOn	ON/OFF		Set E-FLY Default Power State to ON (E-FLY Optional)
		USB Update	YES/NO		Service Port - Software Updates
	Fans Control	Auto , High, Silent		Select Fan Speeds	
	Display Setting	Shutoff Time	02~60m 05m	Display Shut Off Time	
		Display Reverse	ON/AUTO/OFF		Display Reverse 180°
		Key Lock	ON/OFF		Key Lock
	Temperature C/F	Celsius/Fahren		Temperature Switch Between C° / F°	
	Initial Status	PAN =XXX		Initial Effect Position	
	Select Signal	E-FLY Off			E-FLY Wireless Off (E-FLY Optional)
		DMX & E-FLY			DMX In/Out & E-FLY Wireless On (E-FLY Optional)
		E-FLY & Out			Activate E-FLY (Optional) & 5pin DMX OUT
		Art-Net			Select Art-Net
		sACN			Activate sACN
	Ethernet IP	XXX . XXX . XXX . XXX		Ethernet IP (PSWD Required)	
	Ether Mask IP	XXX . XXX . XXX . XXX		Ethernet Mask IP (PSWD Required)	
	Set Universe	000 - 32767		Set ArtNet Universe	
	Set E-FLY Chn	00 - 14		Set E-FLY Wireless Channel (E-FLY Optional)	
	Dimmer Mode	Standard , Stage, TV, Architectural, Theatre, Stage2		Set Dimmer Mode	
Refresh	1200 , 900-1500, 2500, 4000, 5000, 10000, 15000, 20000, 25000		Set LED Refresh Rate (Hz)		
Dimmer Curve	Linear , Square, Inverse Square, S-Curve		Set Dimmer Curve Mode		
Reset Default	ON/OFF	Passcode =	Restore Factory Settings		

(PSWD Required)

ELATION ARTISTE MONET™ - S Y S T E M M E N U**Supports Software Versions: ≥ 1.3.3**

Features subject to change without notice. *Rotation direction (Clockwise/Counterclockwise) and control of effects depends on head orientation and Pan/Tilt settings.

MAIN MENU	SUB MENU	OPTIONS / VALUES (Default Settings in BOLD)		DESCRIPTION	
Reset Function	Reset All			Reset All Motors	
	Reset Pan&Tilt			Reset Pan/Tilt	
	Reset Colors			Reset Colors	
	Reset Gobos			Reset Gobos	
	Reset ZoomModules			Reset Zoom Modules	
	Reset Others			Reset Other Motors	
Effect Adjust	Test Channel	PAN		Test function	
	Manual Control	PAN =XXX,		Fine Adjustments	
	Calibration	Calibration Password		Password 050 (PSWD Required)	
User Mode Set	User Mode	Standard		DMX Channel Modes	
		Extended			
Edit Program	Select Program	Auto Pro Part1 = Program 1~10 (Program 1)		Select Programs To Be Run	
		Auto Pro Part2 = Program 1~10 (Program 2)			
		Auto Pro Part3 = Program 1~10 (Program 3)			
	Edit Program	Program 1	Program Test		Testing Program
		:	Step 01=SCxxx		Program In Loop
		Program 10	Step 64=SCxxx		Save and Exit
	Edit Scenes	Edit Scene 001 ~ Edit Scene 250	Pan,Tilt,.....		Save and Automatically Return
			--Fade Time-- --Scene Time--		Manual Scenes Edit
Input By Outside			Stores Scenes via Ext DMX Console		
Rec. Controller	XX~XX		Automatic Scenes Recorder		



ALTHOUGH E-FLY SETTINGS MAY APPEAR IN THE SYSTEM MENU, THIS FEATURE IS NOT ACTIVATED. E-FLY WIRELESS DMX IS AN OPTIONAL FEATURE WHICH MUST BE ACTIVATED IN THE SERVICE MENU. PLEASE CONTACT ELATION SERVICE FOR FURTHER DETAILS.

SYSTEM MENU CHANGE WITH SOFTWARE UPDATE VERSION ≥1.3.4 and ≥1.4.1

See highlighted menu items below which have been updated with this software update.

ELATION ARTISTE MONET™ - SYSTEM MENU			
Supports Software Versions: ≥ 1.3.4 and ≥ 1.4.1			
Features subject to change without notice. *Rotation direction (Clockwise/Counterclockwise) and control of effects depends on head orientation and Pan/Tilt settings.			
MAIN MENU	SUB MENU	OPTIONS / VALUES (Default Settings in BOLD)	DESCRIPTION
FUNCTION	Set Dmx Address	A001~AXXX	DMX Address Setting
	Dmx Value	ALL.....	DMX Value Display
	Secondary Mode	Secondary1, Secondary2, Secondary3	Secondary Setting
	Auto Program	Primary / Alone	Auto Program
INFORMATION	Time Information	Current Time	XXXX (Hours) Fixture Run Time From Power ON
		Total Run Time	XXXX (Hours) Fixture Total Run Time
		Last Run Time	XXXX (Hours) Fixture Last Run Time
		LastRun Password	Password= 038 (PSWD Required)
		Clear Last Run	ON / OFF Clear Fixture Last Run Time
	Temperature Info	LED Temperature	XXX C° / F° Temperature of LED Engine
		Head Temperature	XXX C° / F° Temperature in Fixture Head
		Base Temperature	XXX C° / F° Temperature in Fixture Base
	Ethernet IP	000 . 000 . 000 . 000 000 . 000 . 000 . 000	Displays Fixture Ethernet Address
	Fan Info	HeadFan: xxxx RPM	Displays Fan Info
	Software Version	1U01: ~ ≥V1.3.3	Software Version
Error Info	Error Record 1 ~ Error Record 10	Fixture Last 10 Error Codes	
PERSONALITY	Status Settings	Address via DMX	ON/OFF Address Via DMX
		No DMX Status	Close / Hold / Auto Fixture State When NO DMX Signal
		Pan Reverse	ON/OFF Pan Reverse Movement
		Tilt Reverse	ON/OFF Tilt Reverse Movement
		Pan Degree	630/ 540 Pan Degree Select
		Feedback	ON/OFF Movement Feedback
		Movement Speed	Normal / Slow Movement Speed
		P/T Brake Mode	Smooth /Fast Pan/Tilt Brake Mode
		Hibernation	OFF, 01M~99M, 15M Stand By Mode
	Service Setting	Password	Password= 050 Service Password
		RDM UID	22A6xxxxxxx RDM PID Code (PSWD Required)
		Clear Err. Info	ON/OFF Clear Error Info (PSWD Required)
		USB Update	YES/ NO Service Port - Software Updates
	Fans Control	Auto , High, Low, Studio, Mute	Select Fan Speeds
	Display Setting	Shutoff Time	02~60m 05m Display Shut Off Time
		Display Reverse	ON/AUTO/ OFF Display Reverse 180°
		Key Lock	ON/ OFF Key Lock
	Temperature C/F	Celsius/ Fahren Temperature Switch Between C°/ F°	
	Initial Status	PAN =XXX	Initial Effect Position
	Service Setting	DMX Only	DMX Only DMX In/Out & E-FLY Wireless On
		Art-Net	Art-Net Select Art-Net
		sACN	sACN Activate sACN
	Ethernet IP	XXX . XXX . XXX . XXX	Ethernet IP (PSWD Required)
	Ether Mask IP	XXX . XXX . XXX . XXX	Ethernet Mask IP (PSWD Required)
	Set Universe	000 - 32767	Set ArtNet Universe
	Dimmer Mode	Standard , Stage, TV, Architectural, Theatre, Stage2, Delay 0s-10s	Set Dimmer Mode
	Refresh	1200 , 900-1500, 2500, 4000, 5000, 6,000 10000, 15000, 20000, 25000 (Hz)	Set LED Refresh Rate
Dimmer Curve	Linear , Square, Inverse Square, S-Curve	Set Dimmer Curve Mode	
Reset Default	ON/OFF Passcode=	Restore Factory Settings (PSWD Required)	

ELATION ARTISTE MONET™ - S Y S T E M M E N U

Supports Software Versions: ≥ 1.3.4 and 1.4.1

Features subject to change without notice.
*Rotation direction (Clockwise/Counterclockwise) and control of effects depends on head orientation and Pan/Tilt settings.

MAIN MENU	SUB MENU	OPTIONS / VALUES (Default Settings in BOLD)	DESCRIPTION	
Reset Function	Reset All		Reset All Motors	
	Reset Pan&Tilt		Reset Pan/Tilt	
	Reset Colors		Reset Colors	
	Reset Gobos		Reset Gobos	
	Reset ZoomModules		Reset Zoom Modules	
	Reset Others		Reset Other Motors	
Effect Adjust	Test Channel	PAN	Test function	
	Manual Control	PAN =XXX,	Fine Adjustments	
	Calibration	Calibration Password	Password 050 (PSWD Required)	
User Mode Set	User Mode	Standard Extended	DMX Channel Modes	
Edit Program	Select Program	Auto Pro Part1 = Program 1~10 (Program 1)	Select Programs To Be Run	
		Auto Pro Part2 = Program 1~10 (Program 2)		
		Auto Pro Part3 = Program 1~10 (Program 3)		
	Edit Program	Program 1	Program Test	Testing Program
		:	Step 01=SCxxx	Program In Loop
		Program 10	Step 64=SCxxx	Save and Exit
	Edit Scenes	Edit Scene 001 ~ Edit Scene 250	Pan,Tilt,.....	Save and Automatically Return
			--Fade Time-- --Scene Time--	Manual Scenes Edit
Input By Outside			Stores Scenes via Ext DMX Console	
Rec. Controller	XX~XX		Automatic Scenes Recorder	

SYSTEM MENU

PERSONALITY - Status Settings - Address Via DMX

When ON, define the desired DMX address via an external controller.

NOTE: This process assumes the fixture DMX address is set to 001. If fixture DMX address is not at 001, you must adjust the channel numbers accordingly in order for this feature to work.

For example: if your fixture address is 010, then Channel 1 becomes Channel 10, Channel 2 becomes Channel 11, and Channel 3 becomes Channel 12.

1. Connect the fixture to the external controller and power ON.
2. Set the DMX value of **Channel 1** on the controller to **(7)**.
3. Set the DMX value of **Channel 2** on the controller to **(7)** or **(8)**.
When set to **(7)**, the DMX address can be set between **(1)** and **(255)**.
When set to **(8)**, the DMX address can be set between **(256)** and **(511)**.
4. Using **Channel 3** on the controller set the desired DMX address of the fixture.

Example 1: If the desired DMX address is **57**, set **Channel 1** to a value of **(7)**, set **Channel 2** to a value of **(7)**, and then set **Channel 3** to a value of **(57)**.

Example 2: If the desired DMX address is **420**, set **Channel 1** to a value of **(7)**, set **Channel 2** to a value of **(8)**, and then set **Channel 3** to a value of **(164)**. ($256+164=420$)

5. After setting **Channel 3** to the desired DMX address value, wait for approximately 20 seconds (some fixtures may require a longer time) for the fixture to complete the address reset function.

PERSONALITY – Service Setting - Password (050)

The Service Password MUST be entered in order to access the service menus.

SYSTEM MENU

PERSONALITY – Service Setting – USB Update

To update the fixture software via the **UPDATE/SERVICE PORT**, follow steps below.



ONLY QUALIFIED TECHNICIANS SHOULD PERFORM THIS FUNCTION!
NOTE ALL MENU SETTINGS BEFORE UPDATING SOFTWARE!
FIXTURE SOFTWARE CAN NOT BE DOWNGRADED!
DOWNLOAD FIXTURE SOFTWARE TO PC ONLY! (NO MAC SUPPORT)
PLEASE CONTACT ELATION SERVICE FOR FURTHER INFORMATION.

1. Copy fixture software update file from a PC computer to a compatible USB flash drive.
Make sure only the fixture software update file is stored on the USB flash drive.
2. Disconnect DMX, Art-Net, and E-FLY connections and power the fixture ON.
3. Insert USB flash drive into the **UPDATE/SERVICE PORT** on the rear connection panel.
4. Navigate to the **Personality** main menu **Service Setting / USB Update** sub menu.
5. Select the software file name on the menu display and press **ENTER**.
6. Select **YES** to begin update process and **Updating...%** will show on the menu display.
7. After file is uploaded, the fixture will check the software which will take some time.
The fixture will perform a reset process when the software update process is complete.
8. Remove the USB flash drive and make necessary system menu setting adjustments.

PERSONALITY - Display Setting – Key Lock

When ON, Control Panel buttons lock automatically after exiting main menu for 15 seconds. To unlock, keep **MODE/ESC** button pressed for 3 seconds.

PERSONALITY - Reset Default



ONLY QUALIFIED TECHNICIANS SHOULD PERFORM THIS FUNCTION!

This function restores all fixture settings to the factory default settings. The password is **011** and must be entered each time a reset is performed.

EFFECT ADJUST – Test Channel

Auto test each individual channel function independently from the DMX control board.

EFFECT ADJUST – Manual Control

Select and manually test and fine adjust each individual channel function

Independently from DMX control board. This function will center PAN and TILT motors and set dimmer to 100%. PAN and TILT functions will still operate if the fixture needs to be positioned to a flat clear surface. With the individual functions, you can focus the light on a flat surface (wall) and perform fine adjustments.

SYSTEM MENU

EFFECT ADJUST – Calibration



ONLY QUALIFIED TECHNICIANS SHOULD PERFORM THIS FUNCTION!

This function allows small adjustments to be made to the Pan, Tilt, and Zoom movements to compensate for wear or in the event a sensor has been knocked slightly out of place. Because improper use of this function can result in undesired operation this function has been password protected. The password is **050** and must be entered each time the calibration menu function is entered. Because calibration is an extremely delicate procedure, instructions on performing this action are left out of this manual. For a first-time calibrator, please contact our customer support team for step-by-step instructions.

EDIT PROGRAM – Rec. Controller

The fixture features an integrated DMX-recorder by which you can transmit the programmed scenes from your DMX-controller to the moving head. Adjust the desired scene numbers via the encoder (from – to). When you call up the scenes at your controller, they will automatically be transmitted to the moving head.

EDIT PROGRAM – Record Controller – Working with Built-In Programs

A Primary unit can send up to 3 different data groups to the Secondary units, i.e. a Primary unit can start 3 different Secondary units, which run 3 different programs. The Primary unit sends the 3 program parts in a continuous loop.

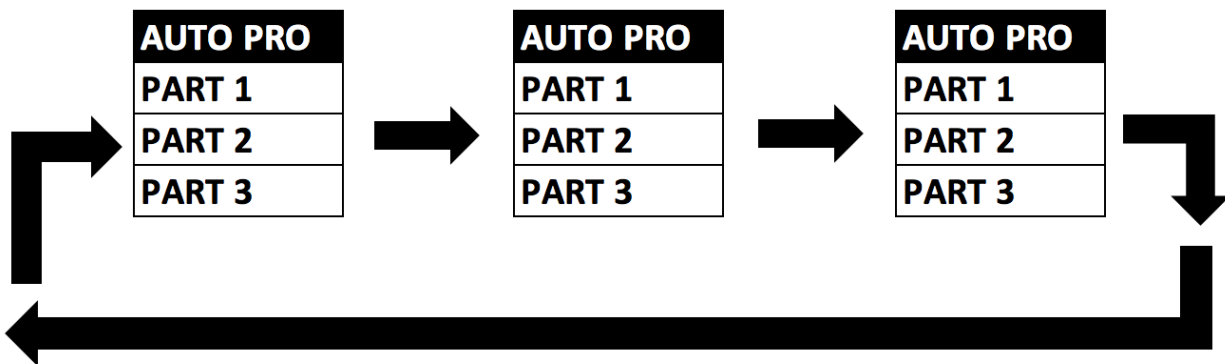

The Secondary unit receives data from the Primary unit according to the group which the Secondary unit was assigned to. If e.g. a Secondary unit is set to “**Secondary 1**” in the menu “**Set to Secondary**”, the Primary unit sends “**Auto Program Part 1**” to the Secondary unit. If set to “**Secondary 2**”, the Secondary unit receives “**Auto Program Part 2**”.

SYSTEM MENU

EDIT PROGRAM – Record Controller – Working with Built-In Program [continued]

To start an Auto Program, proceed as follows:

1. Secondary Setting

Select “**Function Mode**”.

Press **ENTER** to confirm.

Select “**Set to Secondary**”.

Press **ENTER** to confirm.

Select “**Secondary 1**”, “**Secondary 2**” or “**Secondary 3**”.

Press **ENTER** to confirm.

Press **MODE/ESC** in order to return to the main menu.

2. Automatic Program Run

Select “**Function Mode**”.

Press **ENTER** to confirm.

Select “**Auto Program**”.

Press **ENTER** to confirm.

Select “**Primary**” or “**Alone**”.

Press **ENTER** to confirm.

Press **MODE/ESC** in order to return to the main menu.

3. Program Selection for Auto Pro Part

Select “**Edit Program**”.

Press **ENTER** to confirm.

Select “**Select Programs**”.

Press **ENTER** to confirm.

Select “**Auto Pro Part 1**”, “**Auto Pro Part 2**” or “**Auto Pro Part 3**” and select which Secondary program is to be sent. Selection “**Part 1**” means, that the Secondary unit runs the same program as the primary units.

Press **ENTER** to confirm.

Press **MODE/ESC** in order to return to the main menu.

4. Program Selection for Edit Program

Select “**Edit Program**”.

Press **ENTER** to confirm.

Select “**Edit Program**”.

Press **ENTER** to confirm.

Select the desired program to edit specific scenes into a specific program.

Press **ENTER** to confirm.

Press **MODE/ESC** in order to return to the main menu.

SYSTEM MENU

EDIT PROGRAM – Record Controller – Working with Built-In Program [continued]

5. Automatic Scene Recording

Select “**Edit Program**”.

Press **ENTER** to confirm.

Select “**Edit Scenes**”.

Select desired scene numbers. A maximum of 250 scenes can be programmed.

Press **ENTER** to confirm.

Press **MODE/ESC** in order to return to the main menu.

Example:

Program 2 includes scenes: 10, 11, 12, & 13

Program 4 includes scenes: 8, 9, & 10

Program 6 includes scenes: 12, 13, 14, & 15

Auto Pro Part 1 is Program 2

Auto Pro Part 2 is Program 3

Auto Pro Part 3 is Program 6

The 3 Secondary groups run the Auto Program in certain time segments. (See chart below)

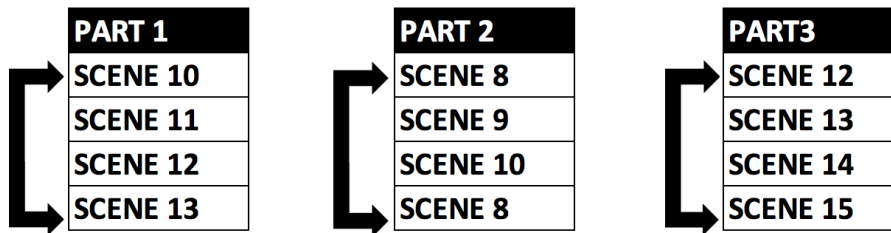

DIMMER CURVES

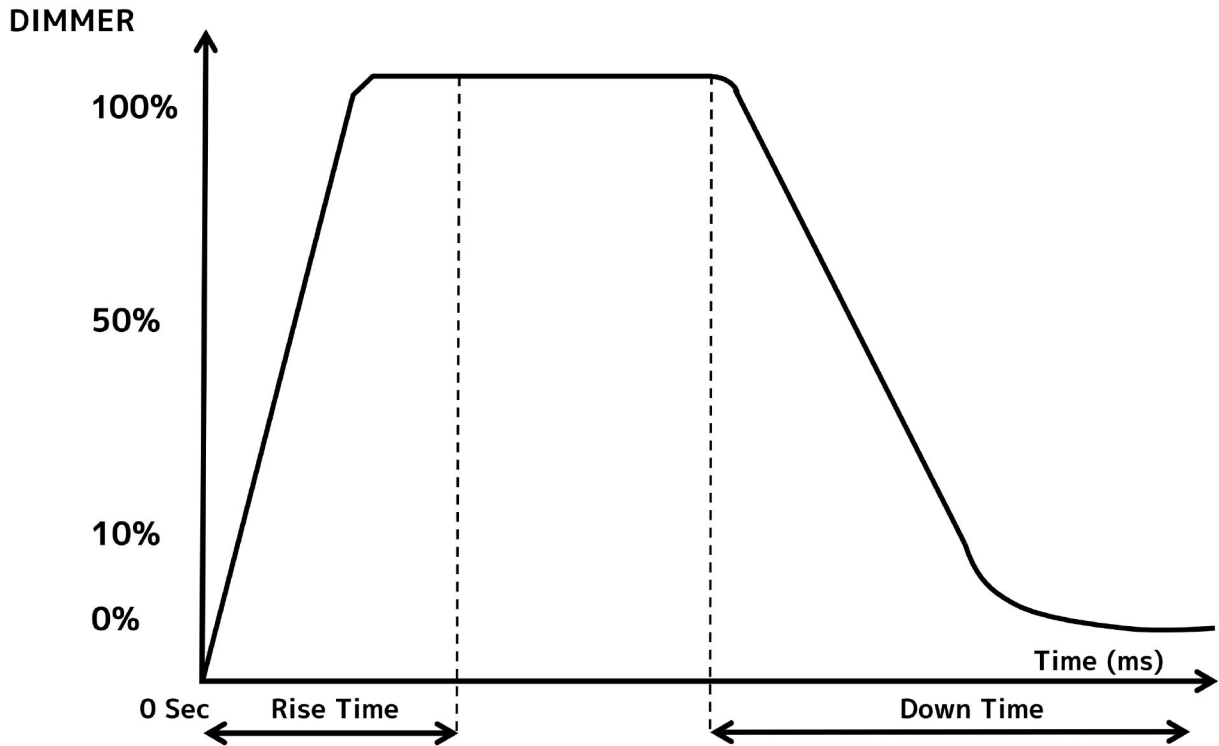

Dimming Curve Ramp Effect	0 sec Fade Time		1 sec Fade Time	
	Rise Time (ms)	Down Time (ms)	Rise Time (ms)	Down Time (ms)
Standard (default)	0	0	0	0
Stage	780	1100	1540	1660
TV	1180	1520	1860	1940
Architectural	1380	1730	2040	2120
Theatre	1580	1940	2230	2280

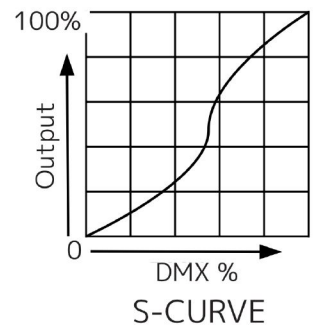
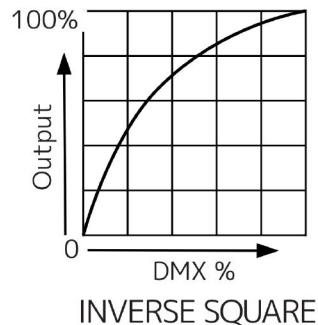
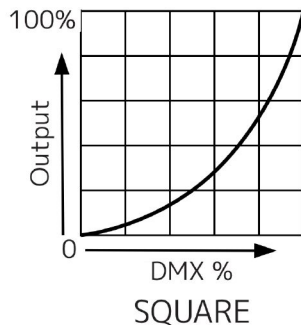
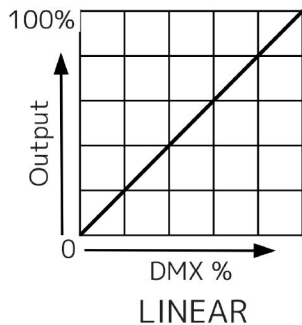

DMX CHANNEL FUNCTIONS AND VALUES

RELATION ARTISTE MONET™						
DMX Channel Values / Functions (67 Total DMX Channels)						
Supports Software Versions: ≥ 1.3.3						
Features subject to change without notice. *Rotation direction (Clockwise/Counterclockwise) and control of effects depends on head orientation and Pan/Tilt settings.						
Standard	Extended	Value	Function	Hold Time	Default	Snap
1	1		PAN		127	
		0-255	Movement			
2	2		PAN FINE		127	
		0-255	Fine Movement			
3	3		TILT		127	
		0-255	Movement			
4	4		TILT FINE		127	
		0-255	Fine Movement			
5	5		CYAN		0	
		0-255	0 → 100%			
	6		CYAN FINE		0	
		0-255	Fine Adjustment			
6	7		MAGENTA		0	
		0-255	0 → 100%			
	8		MAGENTA FINE		0	
		0-255	Fine Adjustment			
7	9		YELLOW		0	
		0-255	0 → 100%			
	10		YELLOW FINE		0	
		0-255	Fine Adjustment			
8	11		CTO		0	
		0-255	0 → 100%			
	12		CTO FINE		0	
		0-255	Fine Adjustment			
9	13		PURE RED MIX		0	
		0-255	0 → 100%			
	14		PURE RED MIX FINE		0	
		0-255	Red Fine			
10	15		PURE GREEN MIX		0	
		0-255	0 → 100%			
	16		PURE GREEN MIX FINE		0	
		0-255	Green Fine			
11	17		PURE BLUE MIX		0	
		0-255	0 → 100%			
	18		PURE BLUE MIX FINE		0	
		0-255	Blue Fine			

Standard	Extended	Value	Function	Hold Time	Default	Snap
12	19		COLOR WHEEL		0	X
		0-19	Open			
		20-37	Red			
		38-55	Green			
		56-73	UV			
		74-91	High CRI			
		92-109	Orange			
		110-127	Medium Blue			
		128-189	Color Scroll CW FAST to SLOW			
		190-193	NO Rotation			
		194-255	Color Scroll CCW SLOW to FAST			
	20		COLOR WHEEL FINE			X
		0-255	Fine Control of Color Wheel Position			
13	21		ROTATING GOBOS [GOBO WHEEL 1]		0	X
		0-9	Open			
		10-19	Rotating Gobo 1			
		20-29	Rotating Gobo 2			
		30-39	Rotating Gobo 3			
		40-49	Rotating Gobo 4			
		50-59	Rotating Gobo 5			
		60-69	Rotating Gobo 6			
		70-77	Rotating Gobo 7			
		78-93	Rotating Gobo 1 Shake SLOW to FAST			
		94-109	Rotating Gobo 2 Shake SLOW to FAST			
		110-125	Rotating Gobo 3 Shake SLOW to FAST			
		126-141	Rotating Gobo 4 Shake SLOW to FAST			
		142-157	Rotating Gobo 5 Shake SLOW to FAST			
		158-173	Rotating Gobo 6 Shake SLOW to FAST			
		174-189	Rotating Gobo 7 Shake SLOW to FAST			
		190-221	Gobo Scroll CW FAST to SLOW			
		222-223	STOP			
224-255	Gobo Scroll CCW SLOW to FAST					
14	22		ROTATING GOBOS INDEXING [GOBO WHEEL 1]		0	
		0-127	Gobo Indexing			
		128-189	Gobo Scroll CW FAST to SLOW			
		190-193	NO Rotation			
		194-255	Gobo Scroll CCW SLOW to FAST			
15	23		ROTATING GOBOS INDEXING FINE [GOBO WHEEL 1]		0	
		0-255	Fine Control of Rotating Gobos Indexing			

Standard	Extended	Value	Function	Hold Time	Default	Snap
16	24		FIXED GOBOS [GOBO WHEEL 2]		0	X
		0-9	Open			
		10-19	Gobo 1			
		20-29	Gobo 2			
		30-39	Gobo 3			
		40-49	Gobo 4			
		50-59	Gobo 5			
		60-69	Gobo 6			
		70-77	Gobo 7			
		78-93	Gobo 1 Shake SLOW to FAST			
		94-109	Gobo 2 Shake SLOW to FAST			
		110-125	Gobo 3 Shake SLOW to FAST			
		126-141	Gobo 4 Shake SLOW to FAST			
		142-157	Gobo 5 Shake SLOW to FAST			
		158-173	Gobo 7 Shake SLOW to FAST			
		174-189	Gobo 8 Shake SLOW to FAST			
		190-221	Gobo Scroll CW FAST to SLOW			
		222-223	NO Rotation			
224-255	Gobo Scroll CCW SLOW to FAST					
	25		FIXED GOBO WHEEL INDEXING [GOBO WHEEL 2]		0	X
		0-255	Fine Control of Fixed Gobo Wheel 2 Indexing			
17	26		ROTATING PRISM, PRISM / GOBO MACROS		0	X
		0-63	Open			
		64-95	4 Prism			
		96-127	4 Facet Linear			
		128-135	Macro1			
		136-143	Macro2			
		144-151	Macro3			
		152-159	Macro4			
		160-167	Macro5			
		168-175	Macro6			
		176-183	Macro7			
		184-191	Macro8			
		192--199	Macro9			
		200-207	Macro10			
		208-215	Macro11			
		216-223	Macro12			
		224-231	Macro13			
		232-239	Macro14			
240-247	Macro15					
248-255	Macro16					

Standard	Extended	Value	Function	Hold Time	Default	Snap
18	27		ROTATING PRISM, PRISM INDEXING		0	
		0-127	Prism Indexing			
		128-189	Prism Rotation CW FAST to SLOW			
		190-193	NO Rotation			
		194-255	Prism Rotation CCW SLOW to FAST			
	28		ROTATING PRISM, PRISM INDEXING FINE		0	
		0-255	Fine Control of Prism Indexing			
19	29		FOCUS		127	
		0-255	Focus Adjustment from NEAR to FAR			
20	30		FOCUS FINE		127	
		0-255	Focus Fine Adjustment from NEAR to FAR			
21	31		ZOOM		127	
		0-255	Zoom Adjustment from SMALL to BIG			
22	32		ZOOM FINE		127	
		0-255	Zoom Fine Adjustment			
	33		AUTO FOCUS		0	X
		0-50	Auto Focus Off			
		51-100	5m			
		101-150	7.5m			
		151-200	10m			
	34		AUTO FOCUS FINE		0	X
		0-255	Fine Control of Focus Adjustment			
23	35		STROBE		50	X
		0-31	Shutter Closed			
		32-63	NO Function (Shutter Open)			
		64-95	Strobe SLOW to FAST			
		96-127	No Function (Shutter Open)			
		128-159	Pulse-effect in sequences			
		160-191	No function (shutter open)			
		192-223	Random strobe effect slow to fast			
224-255	No function (shutter open)					
24	36		DIMMER		0	
		0-255	0 → 100%			
25	37		DIMMER FINE		0	
		0-255	Fine Dimming			

Standard	Extended	Value	Function	Hold Time	Default	Snap
26	38		DIM MODES	0s	0	X
		0-20	Standard			
		21-40	Stage			
		41-60	TV			
		61-80	Architectural			
		81-100	Theatre			
		101-120	Stage 2			
			DIMMER DELAY TIME			
		121	0s			
		122	0.1s			
		123	0.2s			
		124	0.3s			
		125	0.4s			
		126	0.5s			
		127	0.6s			
		128	0.7s			
		129	0.8s			
		130	0.9s			
		131	1.0s			
		132	1.5s			
		133	2.0s			
		134	3.0s			
		135	4.0s			
		136	5.0s			
		137	6.0s			
		138	7.0s			
139	8.0s					
140	9.0s					
141	10s					
	142-255	Idle				

Standard	Extended	Value	Function	Hold Time	Default	Snap
27	39		IRIS		0	
		0-191	MAX Diameter to MIN Diameter			
		192-223	Pulse Closing FAST to SLOW			
		224-255	Pulse Opening SLOW to FAST			
	40		IRIS FINE		0	
		0-255	Fine Control of Iris			
28	41		FROST		0	
		0-127	Open to LIGHT Frost			
		128-255	Open to WASH Frost			
29	42		ANIMATION WHEEL		0	
		0-7	Open			
		8-255	Animation Rotation MIN to MAX			
30	43		ANIMATION WHEEL, INDEX ROATIONI		0	
		0-127	Animation Wheel Indexing			
		128-189	Animation Wheel Rotation CW from FAST to SLOW			
		190-193	No Rotation			
		194-255	Animation Wheel Rotation CW from SLOW to FAST			

Standard	Extended	Value	Function	Hold Time	Default	Snap
	44		SPEED of CMY & Color Macro		0	
		0-255	Speed MAX to MIN			
			COLOR MACROS - CMY & Color Wheel			
		0-31	OFF			
		32-39	Macro1			
		40-47	Macro2			
		48-55	Macro3			
		56-63	Macro4			
		64-71	Macro5			
		72-79	Macro6			
		80-87	Macro7			
		88-95	Macro8			
		96-103	Macro9			
		104-111	Macro10			
		112-119	Macro11			
		120-127	Macro12			
		128-135	Macro13			
	45	136-143	Macro14		0	X
		144-151	Macro15			
		152-159	Macro16			
		160-167	Macro17			
		168-175	Macro18			
		176-183	Macro19			
		184-191	Macro20			
		192-199	Macro21			
		200-207	Macro22			
		208-215	Macro23			
		216-223	Macro24			
		224-231	Macro25			
		232-239	Macro26			
		240-247	Macro27			
		248-255	Random CMY			

Standard	Extended	Value	Function	Hold Time	Default	Snap
31	46		BLADE 1A		0	
		0 -255	Open to Close			
	47		BLADE 1A FINE		0	
		0 -255	Open to Close FINE			
32	48		BLADE 1B		0	
		0 -255	Open to Close			
	49		BLADE 1B FINE		0	
		0 -255	Open to Close FINE			
33	50		BLADE 2A		0	
		0 -255	Open to Close			
	51		BLADE 2A FINE		0	
		0 -255	Open to Close FINE			
34	52		BLADE 2B FINE		0	
		0 -255	Open to Close			
	53		BLADE 2B FINE		0	
		0 -255	Open to Close FINE			
35	54		BLADE 3A		0	
		0 -255	Open to Close			
	55		BLADE 3A FINE		0	
		0 -255	Open to Close FINE			
36	56		BLADE 3B		0	
		0 -255	Open to Close			
	57		BLADE 3B FINE		0	
		0 -255	Open to Close FINE			
37	58		BLADE 4A		0	
		0 -255	Open to Close			
	59		BLADE 4A FINE		0	
		0 -255	Open to Close FINE			
38	60		BLADE 4B		0	
		0 -255	Open to Close			
	61		BLADE 4B FINE		0	
		0 -255	Open to Close FINE			
39	62		FRAMING INDEX ROTATION		127	
		0-127	Frame Indexing (0-360 degrees)			
		128-189	CW Frame Rotation from FAST to SLOW			
		190-193	No Rotation			
		194-255	CCW Frame rotation from FAST to SLOW			
	63		FRAMING ROTATION FINE		127	
		0 -255	Fine Control of Framing Rotation			
	64		FRAMING SPEED		0	
		0 -255	Speed MAX to MIN			

Standard	Extended	Value	Function	Hold Time	Default	Snap
			FRAMING MACROS			
		0-7	OFF			
		8-15	Macro1			
		16-23	Macro2			
		24-31	Macro3			
		32-39	Macro4			
		40-47	Macro5			
		48-55	Macro6			
		56-63	Macro7			
		64-71	Macro8			
		72-79	Macro9			
		80-87	Macro10			
		88-95	Macro11			
		96-103	Macro12			
		104-111	Macro13			
		112-119	Macro14			
	65	120-127	Macro15		0	X
		128-135	Macro16			
		136-143	Macro17			
		144-151	Macro18			
		152-159	Macro19			
		160-167	Macro20			
		168-175	Macro21			
		176-183	Macro22			
		184-191	Macro23			
		192-199	Macro24			
		200-207	Macro25			
		208-215	Macro26			
		216-223	Macro27			
		224-231	Macro28			
		232-239	Macro29			
		240-247	Macro30			
		248-255	Macro31			
			PAN / TILT SPEED			
		0-225	Speed MAX to MIN			
	66	226-235	Blackout by Movement		0	X
		236-245	Blackout by All Wheel Changing			
		246-255	NO Function			

Standard	Extended	Value	Function	Hold Time	Default	Snap
40	67		CONTROL (Changed System Menu Permanently)	0s	0	X
		0-19	Color Change Normal			
		20-29	Color Change to Any Position			
		30-39	Color & Gobo Change to Any Position	3s		
		40-59	Fan Mode Low			
		60-69	Fan Mode High			
		70-79	Fan Mode Auto			
		80-84	All Motor Reset			
		85-87	Pan / Tilt Motors Reset			
		88-90	Color Motors Reset			
		91-93	Gobo Motors Reset			
		94-96	Focus and Zoom Motor Reset			
		97-99	Other Motor Reset			

SOFTWARE UPDATE - DMX Values 40-79 Updated in Software Versions: $\geq 1.3.4$ and $\geq 1.4.1$

40	67		CONTROL (Changed System Menu Permanently)	0s	0	X
		0-19	Color Change Normal			
		20-29	Color Change to Any Position			
		30-39	Color & Gobo Change to Any Position	3s		
		40-44	Low Noise - Mute			
		45-49	Low Noise - Studio			
		50-59	Fan Control - Low			
		60-69	Fan Control - High			
		70-79	Fan Control - Auto (Default)			
		80-84	All Motor Reset			
		85-87	Pan / Tilt Motors Reset			
		88-90	Color Motors Reset			
		91-93	Gobo Motors Reset			
		94-96	Focus and Zoom Motor Reset			
97-99	Other Motor Reset					

Standard	Extended	Value	Function	Hold Time	Default	Snap
40	67		Refresh Rate (Hz)	1s	0	X
		100	900			
		101	910			
		102	920			
		103	930			
		104	940			
		105	950			
		106	960			
		107	970			
		108	980			
		109	990			
		110	1000			
		111	1010			
		112	1020			
		113	1030			
		114	1040			
		115	1050			
		116	1060			
		117	1070			
		118	1080			
		119	1090			
		120	1100			
		121	1110			
		122	1120			
		123	1130			
		124	1140			
		125	1150			
		126	1160			
		127	1170			
128	1180					
129	1190					

Standard	Extended	Value	Function	Hold Time	Default	Snap
40	67	130	1200	1s	0	X
		131	1210			
		132	1220			
		133	1230			
		134	1240			
		135	1250			
		136	1260			
		137	1270			
		138	1280			
		139	1290			
		140	1300			
		141	1310			
		142	1320			
		143	1330			
		144	1340			
		145	1350			
		146	1360			
		147	1370			
		148	1380			
		149	1390			
		150	1400			
		151	1410			
		152	1420			
		153	1430			
		154	1440			
		155	1450			
		156	1460			
		157	1470			
		158	1480			
		159	1490			
		160	1500			
		161	2500			
		162	4000			
		163	5000			
		164	6000			
		165	10000			
		166	15000			
		167	20000			
		168	25000			

Standard	Extended	Value	Function	Hold Time	Default	Snap
40	67	169-180	Idle	3s		X
		181-190	PanTilt Smooth (default)			
		191-200	PanTilt Fast			
		201-210	Dimmer Curve Linear (default)			
		211-220	Dimmer Curve Square			
		221-230	Dimmer Curve Inverse Square			
		231-240	Dimmer Curve S-Curve			
		241	Internal Program 1 (Scene 1-8)			
		242	Internal Program 2 (Scene 9 -16)			
		243	Internal Program 3 (Scene17-24)			
		244	Internal Program 4 (Scene 25-32)			
		245	Internal Program 5 (Scene 33-40)			
		246	Internal Program 6 (Scene 41-48)			
		247	Internal Program 7 (Scene 49~56)			
		248-249	Hibernate Off			
		250-251	Hibernate			
	252-255	Idle				

ERROR CODES

When power is applied, the unit will automatically enter a “Reset/Test” mode. This mode brings all the internal motors to a home position. If there is an internal problem with one or more of the motors an error code will flash in the display in the form of “XXEr” where as XX will represent a function number. For example, when the display shows “0Er” it means there is some type of error with the Pan motor. If there are multiple errors during the start-up process they will all flash in the display. For example: if the fixtures has errors on **Channel 1, 2, and 5** all at the same time, you will see the error message “01Er”, “02Er”, and ”05Er” flash repeated 5 times.

If an error does occur during the initial start-up procedure the fixture will self-generate a second reset signal and try to realign all the motors and correct the errors. If the error persists after a second attempt a third attempt will be made. If after a third attempt all the errors have not been corrected the fixture will make the following determinations:

3 or More Errors - The fixture cannot function properly with three or more errors therefore the fixture will place itself in a stand-by mode until subsequent repairs can be made.

Less Than 3 Errors - The fixture has less than 3 errors; therefore, most other functions will work properly. The fixture will attempt to operate normally until the errors can be correct by a technician. The errors in question will remain flashing in the display as a reminder of internal errors.

Error Codes subject to change without notice.	
ERROR CODES	DESCRIPTION
PAN Er	Movement is not located in the default position after the reset. This message will appear after a fixture reset if the magnetic-indexing circuit malfunctions (sensor failed, or magnet is missing) or there is a motor failure (defective motor or a defective motor IC drive on the main PCB). This error may also be displayed if the head/yoke was blocked during a reset function.
TILT Er	
Cyan Color Wheel Er	Movement is not located in the default position after the reset. This message will appear after a fixture reset if the magnetic-indexing circuit malfunctions (sensor failed, or magnet is missing) or there is a motor failure (defective motor or a defective motor IC drive on the main PCB).
Magenta Color Wheel Er	
Yellow Color Wheel Er	
CTO Wheel Er	
Color Wheel Er	
Focus Wheel Er	
Zoom Wheel Er	
Iris Er	
AllBladeRotation Er	
Prism1 Er	
Prism2 Er	
Prism_Rot1 Er	
Prism_Rot1 Er	
Animation Er	
AnimationRot Er	

SPECIFICATIONS

SOURCE

950W 6,500K Bright White LED Engine

30,000 Hour Average LED Life*

*Test lab conditions. May vary depending on several factors including but not limited to: Environmental Conditions, Power/Voltage, Usage Patterns (On-Off Cycling), Control, and Dimming.

PHOTOMETRIC DATA

45,000 Total Lumen Output

CRI 72+ (84 with HCRI Filter)

Zoom Range 6.8° - 55°

Beam Angle 4.8° - 41.2°

Field Angle 6.1° - 51°

EFFECTS

Motorized Zoom (large 160mm front lens)

4 Rotating Full Blackout Framing Blades

360° Continuous Framing Index and Rotation

Full 360° Bi-Directional Animation Wheel

4-Facet and Linear Rotating Prisms

2 Variable Frost Filters (Light and Wash)

Internal Color, Framing, Prism, and Frost Macros

Motorized Iris with Variable Pulse Effects

Variable 16-bit Dimming Curve Modes

High Speed Electronic Shutter and Strobe

DMX Controllable LED Refresh Rate

Pan Angle: 540°/630°

Tilt Angle: 250°

COLOR

SpectraColor CMY + RGB Color Mixing Array

6 Dichroic Colors including High CRI Filter and UV

UV

Linear CTO Color Correction

GOBOS

2 Gobo Wheels

7 Rotating / Indexing Interchangeable Glass

Gobos

7 Static Interchangeable Glass Gobos

CONTROL / CONNECTIONS

2 DMX Channel Modes (40 / 67)

16-bit Pan, Tilt and Dimming Control

Motorized Focus and Auto-Focus Presets

DMX Controllable Variable Fan Modes

DMX, RDM, Art-NET, sACN Protocol Support

(6) Button Touch Control Panel

Full Color 180° Reversible LCD Menu Display

Hibernation Mode (Power Save)

Locking 5pin XLR DMX, RJ45 Ethernet, and

Power

USB Connection (Firmware Updates)

With Wired Digital Communication Network

SIZE / WEIGHT

Length: 18.55 in (471.09mm)

Width: 22.97 in (583.37mm)

Height: 31.51 in (800.40mm)

Weight: 94.0 lbs. (42.6kg)

ELECTRICAL / THERMAL

AC 100-240V 50/60Hz

Max Power Consumption: 1400W

BTU/hr (+/- 10%) 4456.87

APPROVALS / RATINGS

CE | cETLus | IP20



Specifications and improvements in the design of this unit and this manual are subject to change without notice.

DIMENSIONAL DRAWINGS - FIXTURE

*DRAWINGS NOT TO SCALE

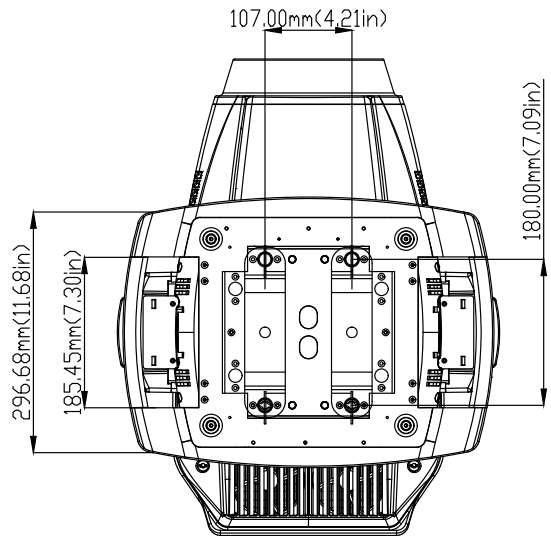
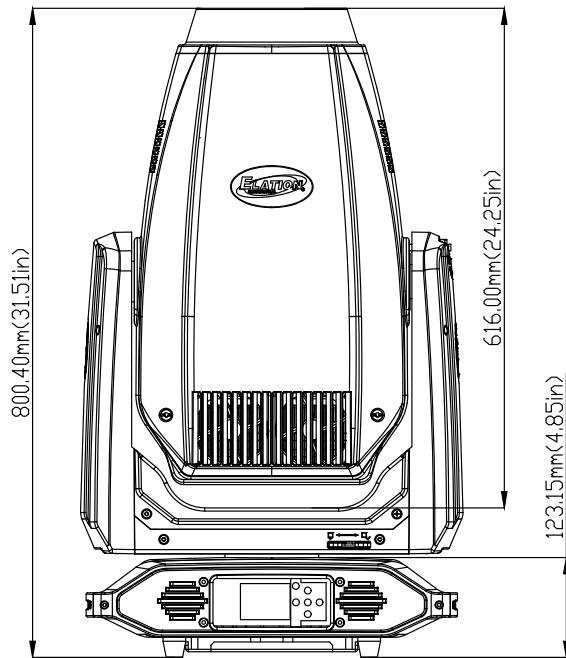
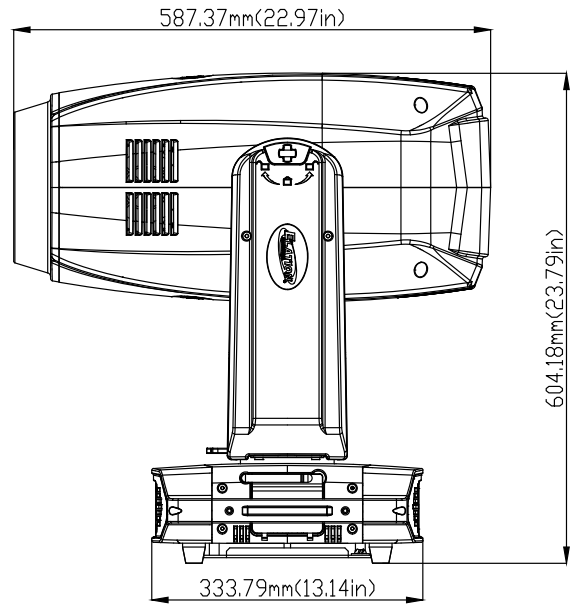
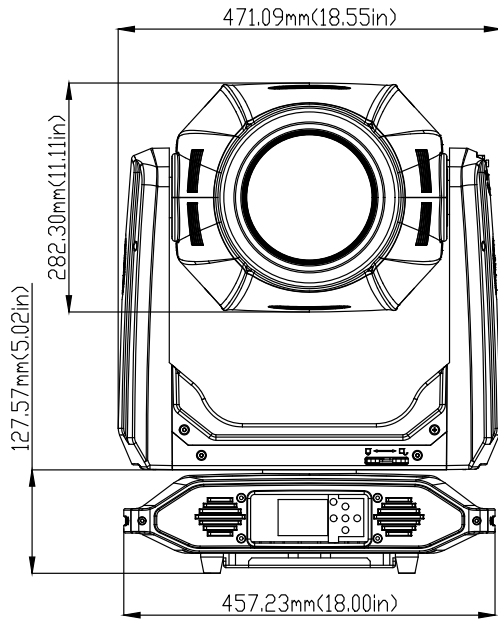

Specifications and improvements in the design of this unit and this manual are subject to change without notice.

DIMENSIONAL DRAWINGS - FIL

*DRAWINGS NOT TO SCALE

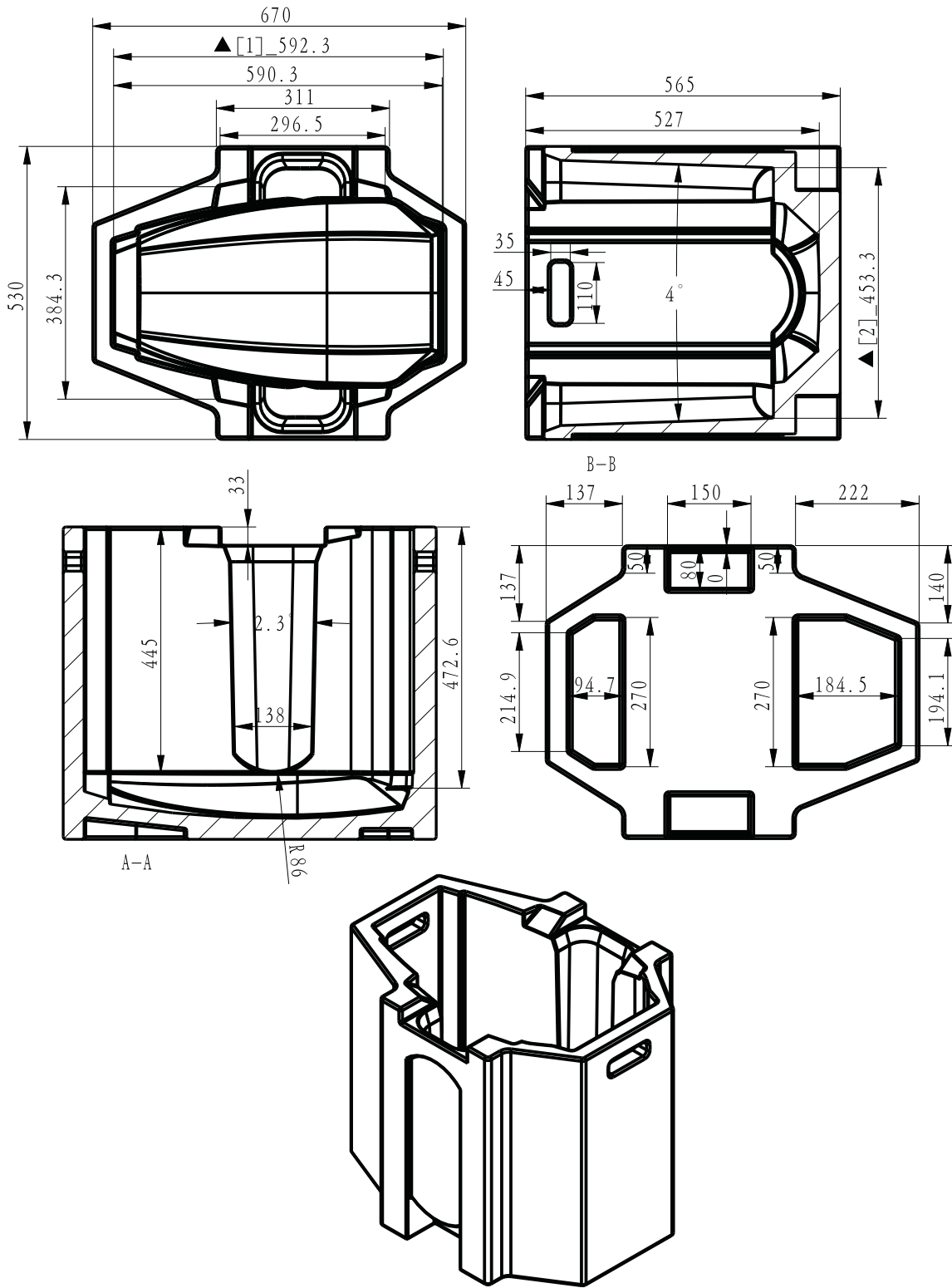

OPTIONAL ACCESSORIES

ORDER CODE	ITEM
603030515290	Gobo Washer * * * SPECIAL ORDER ITEM * * *
DRCPRO001	Dual Pro Road Case Artiste Monet/Proteus Maximus
TRIGGER CLAMP	Heavy Duty Wrap Around Hook Style Clamp
AC5PDMX5PRO	5 ft. (1.5m) 5pin PRO DMX Cable
CAT6PRO5	5 ft. (1.5m) CAT6 Cable
	Additional Cable Lengths Available



FCC STATEMENT

This device complies with Part 15 of the FCC Rules. Operation is subject to the following two conditions: (1) this device may not cause harmful interference, and (2) this device must accept any interference received, including interference that may cause undesired operation.

FCC RADIO FREQUENCY INTERFERENCE WARNINGS & INSTRUCTIONS

This product has been tested and found to comply with the limits as per Part 15 of the FCC Rules. These limits are designed to provide reasonable protection against harmful interference in a residential installation. This device uses and can radiate radio frequency energy and, if not installed and used in accordance with the included instructions, may cause harmful interference to radio communications. However, there is no guarantee that interference will not occur in a particular installation. If this device does cause harmful interference to radio or television reception, which can be determined by turning the device off and on, the user is encouraged to try to correct the interference by one or more of the following methods:

- Reorient or relocate the device.
- Increase the separation between the device and the receiver.
- Connect the device to an electrical outlet on a circuit different from which the radio receiver is connected.
- Consult the dealer or an experienced radio/TV technician for help.

Europe Energy Saving Notice

Energy Saving Matters (EuP 2009/125/EC)

Saving electric energy is a key to help protecting the environment. Please turn off all electrical products when they are not in use. To avoid power consumption in idle mode, disconnect all electrical equipment from power when not in use. Thank you

