

EXPOLITE

ProPAR X3 COB

Bedienungsanleitung User Manual

Art.Nr.: led28305

Eigenschaften
Bedienelemente
Steuerung

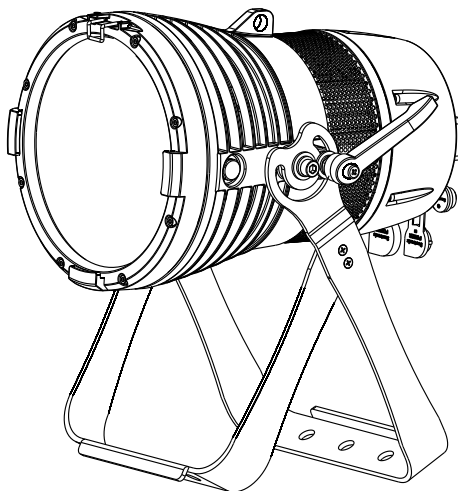

Specifications
Menu
Control

Bedienungsanleitung bitte aufbewahren
Keep this Manual for later queries

Änderungen sind ohne Ankündigung möglich.
Changes are possible without prior notice.
Rev. 2019-07-31



Die beiliegenden Bedienhinweise für Expolite Geräte sind Bestandteil dieser Bedienungsanleitung. Lesen Sie diese sorgfältig, bevor Sie das Gerät in Betrieb nehmen.

The enclosed General Information for Expolite Units are part of these user manual. Read them carefully before operating the device.



by

FOCON SHOWTECHNIC
Vertriebsgesellschaft mbH
Teichweg 4+6
D-49504 Lotte/Wersen

Telefon: ++49 (0) 541-77095-0
Fax: ++49 (0) 541-77095-27

info@focon-showtechnic.com
www.focon-showtechnic.com



Inhalt - Content

	Inhalt - Content	Seite / Page
DE	Lieferumfang	D-04
	Technische Daten	D-05
	Abmessungen	D-06
	Installation	D-07
	Bedienung	D-08
	Steuerung mit DMX512	D-14
ENG	Delivery	E-22
	Product Information	E-23
	Dimensions	E-24
	Installation	E-25
	Operation	E-26
	Using DMX512 Controller	E-32



Lieferumfang

- Expolite ProPAR X3 COB
- Anschlusskabel für Spannungsversorgung
- Bedienhinweise für Expolite Geräte
- Bedienungsanleitung

Expolite Geräte werden vor dem Versand sorgfältig geprüft. Sollte der Lieferumfang dennoch nicht vollständig sein, wenden Sie sich bitte umgehend an Ihren Vertriebspartner.

Technische Daten

Spannungsversorgung	100V - 240V AC 50/60Hz
Maximale Leistungsaufnahme	145W
Abmessungen	320 x 217 x 418mm
Gewicht	6,5kg
Anschlüsse	Power In/Out DMX In/Out
Betriebstemperatur	-20°C - 45°C
Luftfeuchtigkeit*	< 80%
Schutzklasse	IP 65
Gehäuse	Aluminiumdruckguss Gehäuse
LEDs	1x 150W RGBACL
LED Treiberstrom	1A
Abstrahlwinkel	16°
Steuerung	Stand-Alone / DMX512 / RDM
DMX-Kanäle	3 - 20 (3/6/7/10/13/20)

* Siehe Allgemeine Bedienhinweise für Expolite Geräte - Hinweise zu Kondenswasserbildung im Geräteinneren.

ILLUMINANCE AT DISTANCE

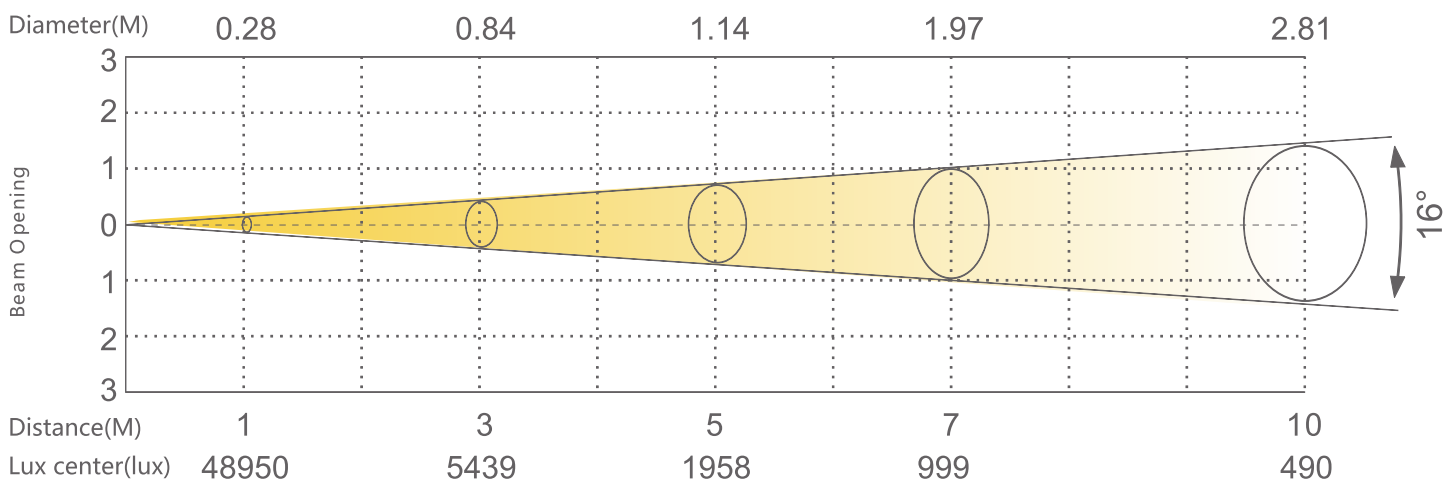

Abmessungen

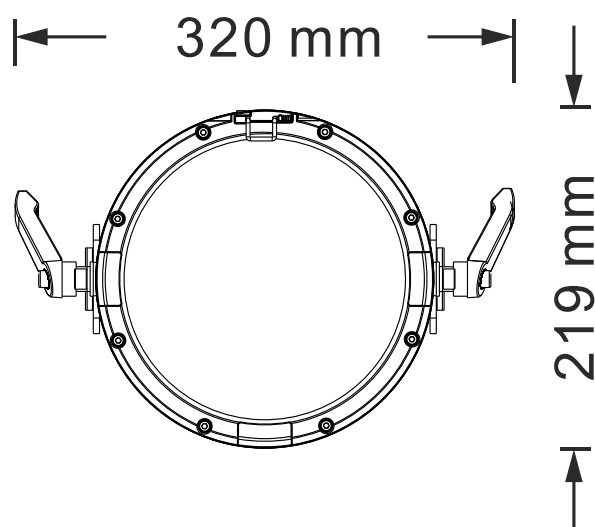
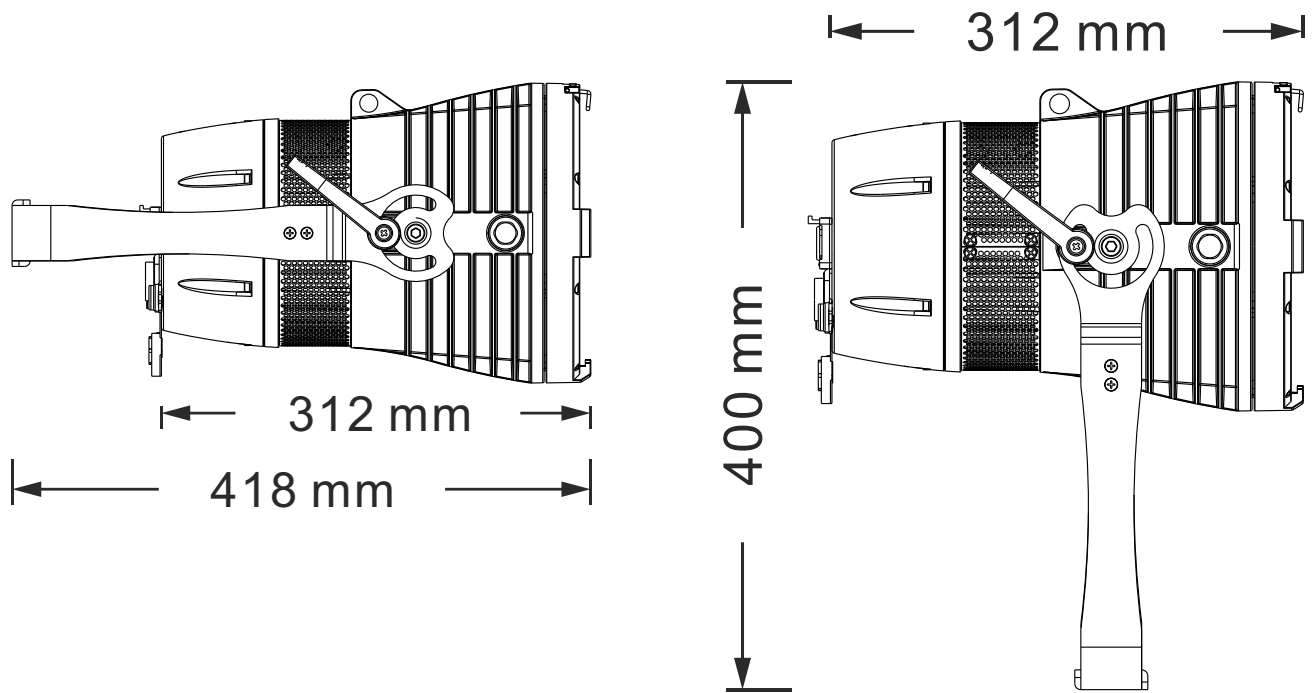

Installation

Montage

Hängend

Das Gerät kann in jeder beliebigen Position verwendet werden. An dem Montagebügel sind Bohrungen vorhanden, durch die gängige Halterungen sicher montiert werden können. Geräte müssen entsprechend der jeweils gültigen Vorschriften sicher montiert und mit einer zweiten Sicherung gegen Herabfallen versehen werden. Hierzu ist am Gerät eine Öse für Safeties angebracht.

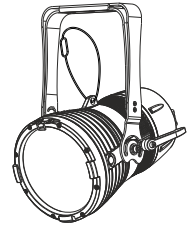

Stehend

Das Gerät kann direkt auf den montierten Bügel gestellt werden. Hierzu muss dieser bis in den mechanischen Anschlag aufgeklappt werden.

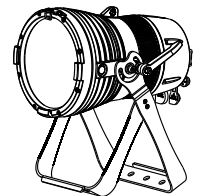

HINWEIS

Das LED Modul kann in jeder beliebigen Lage betrieben werden.

Verbindung der Spannungsversorgung

Bei 230V Netzspannung: maximal 12 Geräte in Reihe.

Bei 110V Netzspannung: maximal 6 Geräte in Reihe.

DMX-Verbindung

Die Geräte mit geeigneten DMX-Kabeln miteinander und mit dem Controller verbinden. Die vorgesehenen DMX-Adressen und Personalities an den Geräten einstellen.

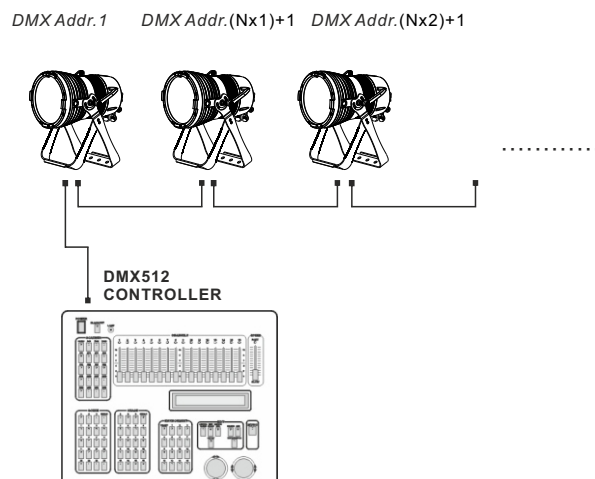

Bedienung

Bedienelemente am Gerät

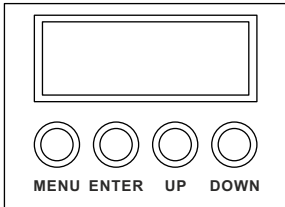

MENU - Taste: Eine Menüebene aufwärts
 ENTER-Taste: In gewähltes Menü springen; Eingabe bestätigen
 UP-Taste: Aufwärts blättern; Wert erhöhen
 DOWN-Taste: Abwärts blättern; Wert verringern

Menüstruktur

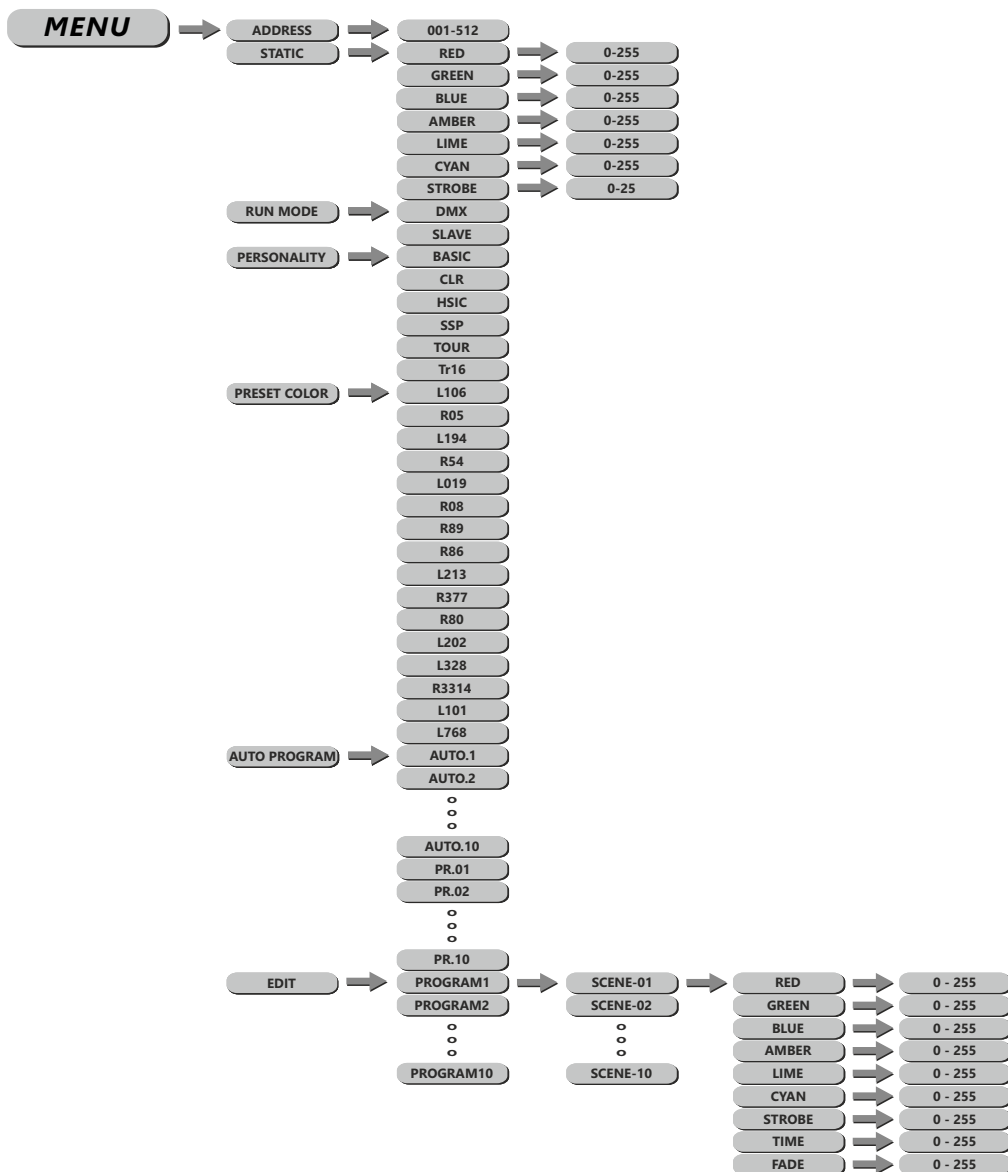

EXPOLITE

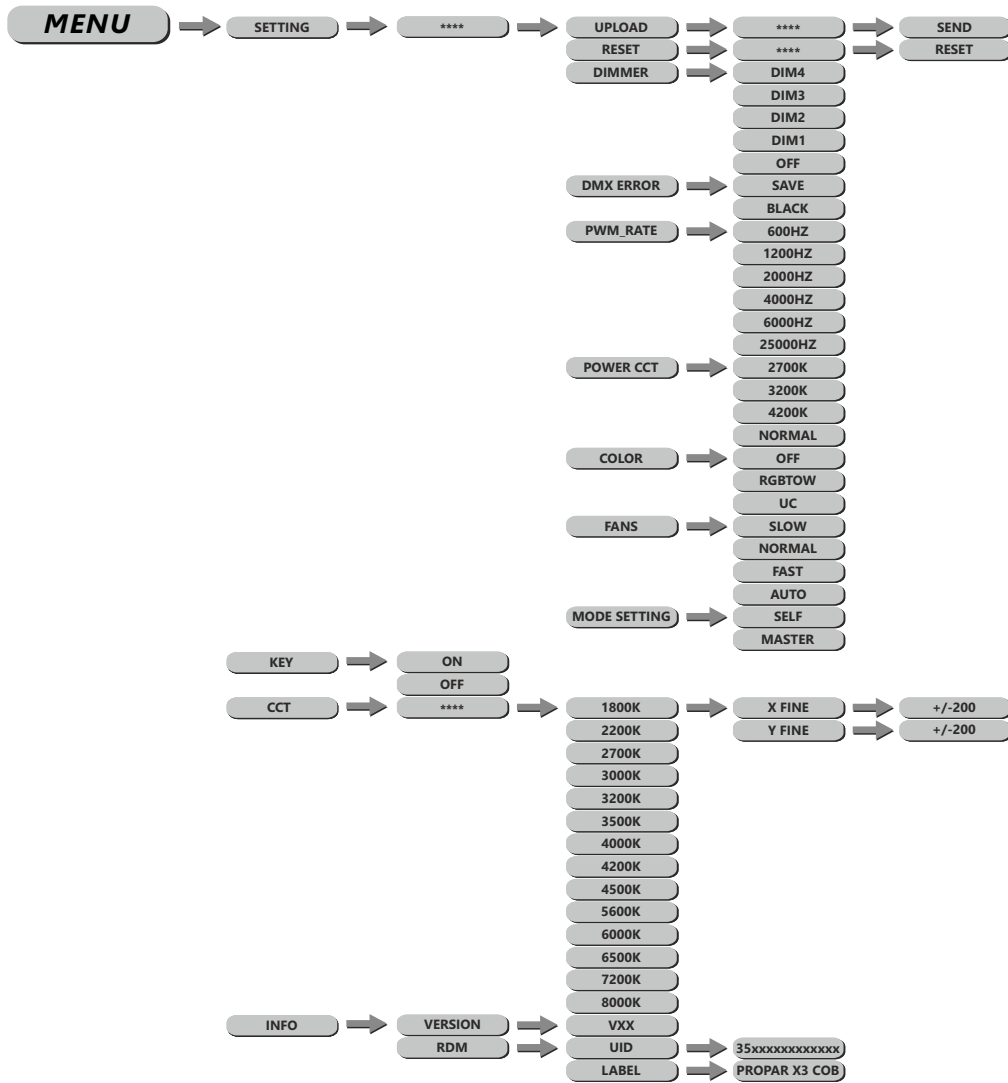

DMX-Adresse einstellen



Im Menü **ADDRESS** wird die DMX-Startadresse des Gerätes eingestellt. Diese bleibt auch bei dem Wechsel der Personality erhalten.

DMX-Kanalbelegung einstellen

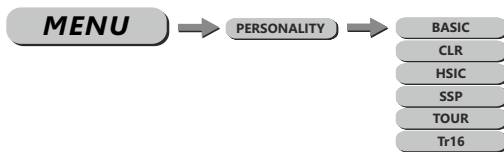

Im Menü **PERSONALITY** wird die Belegung der DMX-Kanäle des Gerätes festgelegt. Es stehen die Modi **BASIC** (3 Kanäle), **CLR** (6 Kanäle), **HSIC** (7 Kanäle), **SSP** (10 Kanäle), **TOUR** (13 Kanäle) und **TR16** (20 Kanäle) zur Verfügung.

Statische Farbe einstellen

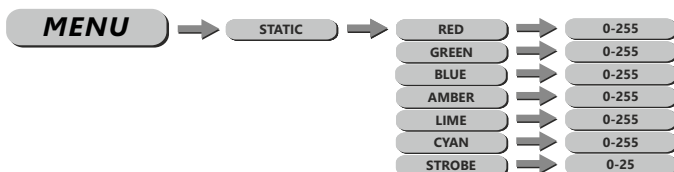

Im Menü werden im Punkt **STATIC** statische Farben für den Stand-Alone Betrieb eingestellt. Diese werden anhand der DMX-Werteskala 0-255 für Rot (**RED**), Grün (**GREEN**), Blau (**BLUE**), Gelb (**AMBER**), Hellgrün (**LIME**) und (**CYAN**), sowie dem Stroboskopwert 0-25Hz (**STROBE**) gemischt.

Vorgespeicherte statische Farbe einstellen

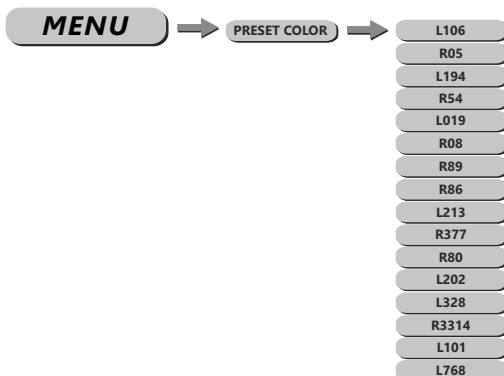

Im Menü **PRESET COLOR** können bestimmte, im Gerät gespeicherte Farben nach RAL- (**R**) und LEE-Farbkatalog (**L**) ausgewählt werden.

Automatikprogramme abspielen

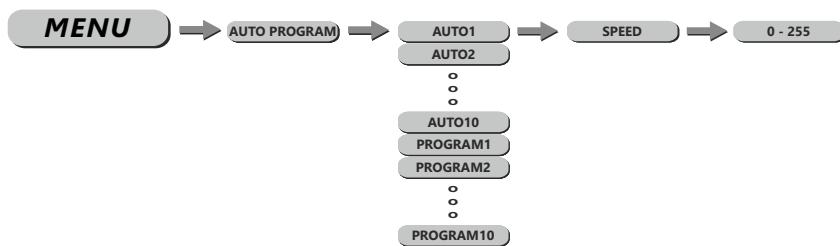

Im Menü werden im Punkt **AUTO PROGRAM** die im Gerät gespeicherten Automatikprogramme abgespielt. Die Programme **AUTO1** bis **AUTO10** sind fest im Gerät hinterlegt. Die Programme **PROGRAM1** bis **PROGRAM10** sind editierbar. Dies wird unter **Editieren benutzerdefinierter Programme** beschrieben. Automatikprogramme werden als Master an verbundene Slave-Geräte übertragen. Für den Master-Slave-Betrieb werden Signale über die DMX-Leitung gesendet. Dies kann dritte Geräte stören.

Runmode auswählen



Im Menü **RUN MODE** wird der Betriebsmodus eingestellt. Für den Betrieb an einem DMX-Kontroller muss **DMX** aktiviert werden. Im Modus **SLAVE** wird das Gerät von einem Master-Gerät gesteuert.

Editieren benutzerdefinierter Programme

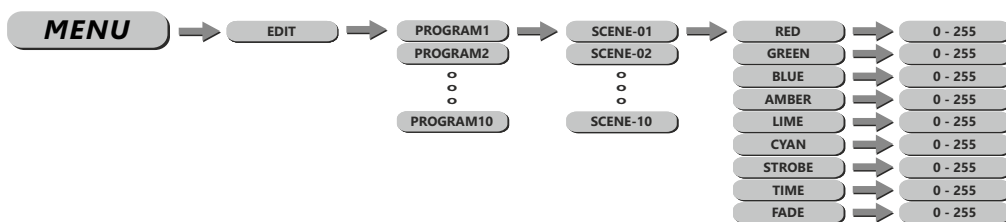

Im Menü **EDIT** werden die Benutzerprogramme **PROGRAM1** bis **PROGRAM10** editiert.

Jedes Programm kann aus bis zu 10 Schritten bestehen (**SCENE-01** - **SCENE-10**). Jeder Schritt besteht aus den Parametern Farbe **RGBALC**, Stroboskop (**STROBE**) „0-25Hz“, Dauer des Steps (**TIME**) und Überblendzeit (**FADE**).

Benutzerprogramme können auf andere Geräte überspielt werden, siehe Master-/Slave Menü.

HINWEIS: Für weniger als 10 Schritte müssen **TIME** und **FADE** des letzten Schrittes auf 0 gesetzt werden.

Beispiel für Time-Settings eines Stand-Alone Programmes mit 3 Schritten:

Step 1 **TIME** = 4 **FADE** = 3
 Step 2 **TIME** = 5 **FADE** = 2
 Step 3 **TIME** = 0 **FADE** = 0

Verschiedene Einstellungen

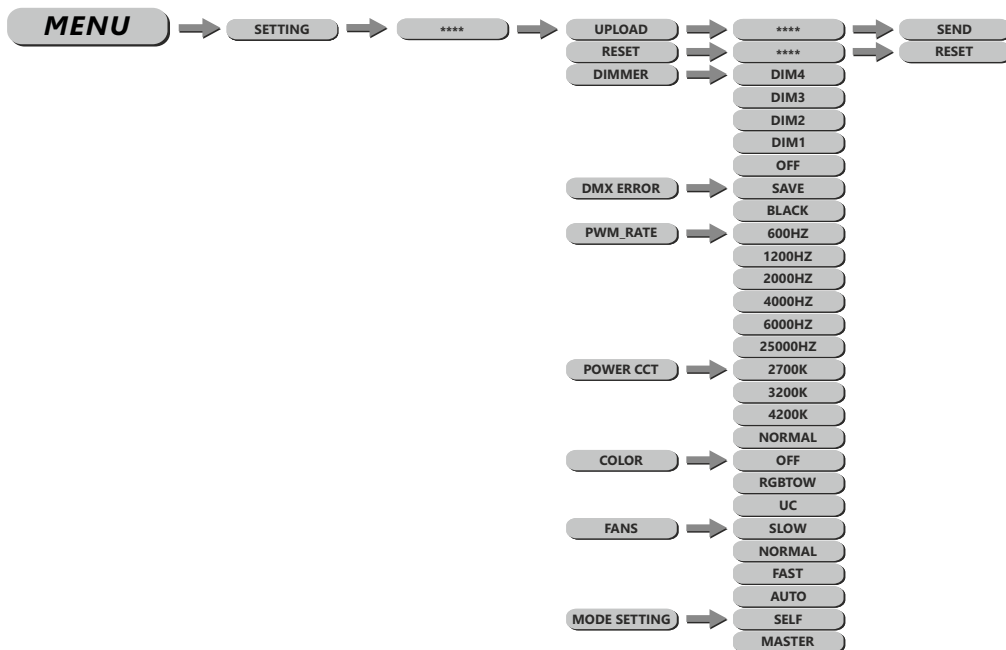

Das Passwort lautet: **UP - DOWN - UP - DOWN - ENTER**

UPLOAD: sendet die benutzerdefinierten Programme an verbundene Slave-Geräte.

RESET: setzt die editierbaren Einstellungen zurück auf die Werkseinstellungen.

DIMMER: stellt die gewünschte Dimmkurve zur Simulation eines Halogenleuchtmittels ein (**OFF/ DIM1/DIM2/DIM3/DIM4**).

DMX ERROR: stellt das Verhalten bei Unterbrechung des DMX-Signals ein. **SAVE** um den letzten empfangenen Wert zu halten, oder **BLACK** für Blackout.

PWM_RATE: bietet die Möglichkeit die PWM-Frequenz des Gerätes anzupassen (**600HZ/1200HZ/ 2000HZ/2400HZ/6000HZ/25000HZ**).

POWER CCT: wählt die Farbtemperatur bei vollem Output. **2700K/3200K/4200K** und **NORMAL** können eingestellt werden.

COLOR: bietet die Möglichkeit eine Farbkalibrierung auszuwählen. Unter **UC** wird der Uniform-Color-Modus aktiviert, der die werksseitige Angleichung aller Geräte der Tour-LED Familie abrufen. Unter **RGBTOW** werden die unter **CCT\RGBTOW** eingestellten Werte verwendet. Bei **OFF** wird keine Kalibrierung genutzt. So erreicht das Gerät die maximale Helligkeit.

FANS: Die Geschwindigkeit des verbauten Lüfters kann in drei Stufen langsam (**SLOW**), normal (**NORMAL**) oder schnell (**FAST**) fest eingestellt werden oder über die Option **AUTO** entsprechend der aktuellen Temperatur der LED-Einheit automatisch vom Gerät geregelt werden.

MODE SETTING: legt fest, ob das Gerät Daten als Master an andere Geräte sendet (**MASTER**) oder nicht (**SELF**).

Aktivieren des Passwortschutzes



Im Menüpunkt **KEY** wird der Passwortschutz des Gerätes bei Gerätestart aktiviert oder deaktiviert. Wenn **KEY** auf **ON** gestellt ist, startet das Gerät gesperrt und das Menü wird jeweils 30 Sekunden nach der letzten Eingabe erneut gesperrt. Für Änderungen im Menü muss dann das Passwort **UP - DOWN - UP - DOWN - ENTER** eingegeben werden.

Kalibrierung und Weißabgleich

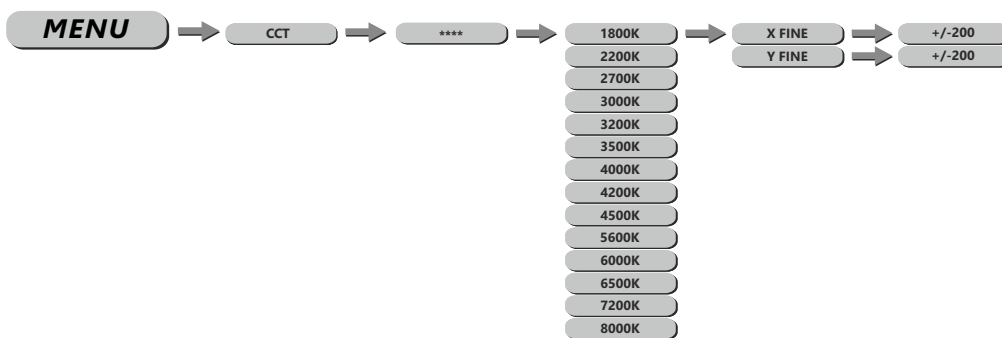

Im Menü **CCT**, Untermenü **CCT** können die vorprogrammierten Farbtemperaturen über **X FINE** und **Y FINE (+/-200)** geändert werden.

Info-Menü



Im Info-Menü (**INFO**), Untermenü **VERSION** wird die z.Zt. installierte Firmwareversion des Gerätes angezeigt.

Im Untermenü **RDM** kann im Untermenü **UID** die **RDM-ID** des Gerätes und im Untermenü **LABEL** die Bezeichnung des Gerätes eingesehen werden.

Steuerung mit DMX512

DMX-Kanalbelegung

Dieses Gerät verfügt über verschiedene DMX-Personalities. Bei diesen werden unterschiedlich viele DMX-Kanäle belegt und die Reaktion des Gerätes unterscheidet sich entsprechend.

Es sind 6 DMX-Personalities (3-/6-/7-/10-/13-/20-Kanäle) wählbar.

Durch Änderungen in der Gerätesoftware kann es zu weiteren oder geänderten Funktionen kommen.

Auf der Website steht das aktuellste Dokument „DMX-Channels“ als pdf zum Download zur Verfügung.

BASIC		
1	0-255	Master Dimmer
2		Preset Colours
	0-11	No Function
	11-20	L106
	21-30	R05
	31-40	L194
	41-50	R54
	51-60	L019
	61-70	R08
	71-80	R89
	81-90	R86
	91-100	L213
	101-110	R377
	111-120	R80
	121-130	L202
	131-140	L328
	141-150	R3314
151-160	L101	
161-170	L768	
171-255	No Function	
3		Colour Macro & White
	0-10	No Function
	11-30	Red 100% / Green Up / Blue 0%
	31-50	Red Down / Green 100% / Blue 0%
	51-70	Red 0% / Green 100% / Blue Up
	71-90	Red 0% / Green Down / Blue 100%
	91-110	Red Up / Green 0% / Blue 100%
	111-130	Red 100% / Green 0% / Blue Down
	131-150	Red 100% / Green Up / Blue Up
	151-170	Red Down / Green Down / Blue 100%
	171-195	All Led at Full Output
	196-199	1800K
	200-203	2200K
	204-207	2700K
	208-211	3000K
212-215	3200K	

EXPOLITE

3	216-219	3500K
	220-223	4000K
	224-227	4200K
	228-231	4500K
	232-235	5600K
	236-239	6000K
	240-243	6500K
	244-247	7200K
	248-255	8000K

CLR		
1	0-255	Red
2	0-255	Green
3	0-255	Blue
4	0-255	Amber
5	0-255	Lime
6	0-255	Cyan

SSP		
1	0-255	Master Dimmer
2	0-255	Dimmer Fine
3	0-255	Red
4	0-255	Green
5	0-255	Blue
6	0-255	Amber
7	0-255	Lime
8	0-255	Cyan
9		Strobe
	0-9	No Function
	10-99	Strobe (Slow to fast)
	100-109	No Function
	110-179	Lightning Strobe
	180-189	No Function
190-255	Random Strobe	
10		Dimmer Speed
	0-9	No Function
	10-29	Off
	30-69	Dim1
	70-129	Dim2
	130-189	Dim3
190-255	Dim4	

EXPOLITE

HSIC		
1	0-255	Intensity
2	0-255	Hue
3	0-255	Hue Fine
4	0-255	Saturation
5		Colour Temperature
	0-10	No Function
	11-28	1800K
	29-46	2200K
	47-64	2700K
	65-82	3000K
	83-100	3200K
	101-118	3500K
	119-136	4000K
	137-154	4200K
	155-172	4500K
	173-190	5600K
	191-208	6000K
	209-226	6500K
	227-244	7200K
245-255	8000K	
6		Strobe
	0-9	No Function
	10-99	Strobe (Slow to fast)
	100-109	No Function
	110-179	Lightning Strobe
	180-189	No Function
190-255	Random Strobe	
7		Dimmer Speed
	0-9	No Function
	10-29	Off
	30-69	Dim1
	70-129	Dim2
	130-189	Dim3
190-255	Dim4	

EXPOLITE

TOUR		
1	0-255	Master Dimmer
2	0-255	Red
3	0-255	Green
4	0-255	Blue
5	0-255	Amber
6	0-255	Lime
7	0-255	Cyan
8		Preset Colours
	0-11	No Function
	11-20	L106
	21-30	R05
	31-40	L194
	41-50	R54
	51-60	L019
	61-70	R08
	71-80	R89
	81-90	R86
	91-100	L213
	101-110	R377
	111-120	R80
	121-130	L202
	131-140	L328
	141-150	R3314
151-160	L101	
161-170	L768	
171-255	No Function	
9		Colour Macro & White
	0-10	No Function
	11-30	Red 100% / Green Up / Blue 0%
	31-50	Red Down / Green 100% / Blue 0%
	51-70	Red 0% / Green 100% / Blue Up
	71-90	Red 0% / Green Down / Blue 100%
	91-110	Red Up / Green 0% / Blue 100%
	111-130	Red 100% / Green 0% / Blue Down
	131-150	Red 100% / Green Up / Blue Up
	151-170	Red Down / Green Down / Blue 100%
	171-195	All Led at Full Output
	196-199	1800K
	200-203	2200K
	204-207	2700K
	208-211	3000K
212-215	3200K	
216-219	3500K	

EXPOLITE

9	220-223	4000K
	224-227	4200K
	228-231	4500K
	232-235	5600K
	236-239	6000K
	240-243	6500K
	244-247	7200K
	248-255	8000K
10		Auto
	0 - 40	No Function
	41-50	Auto 1
	51-60	Auto 2
	61-70	Auto 3
	71-80	Auto 4
	81-90	Auto 5
	91-100	Auto 6
	101-110	Auto 7
	111-120	Auto 8
	121-130	Auto 9
	131-140	Auto 10
	141-150	Program 1
	151-160	Program 2
	161-170	Program 3
	171-180	Program 4
	181-190	Program 5
	191-200	Program 6
201-210	Program 7	
211-220	Program 8	
221-230	Program 9	
231-255	Program 10	
11	0-255	Auto Speed Adjustment
12		Strobe
	0-9	No Function
	10-99	Strobe (Slow to fast)
	100-109	No Function
	110-179	Lightning Strobe
	180-189	No Function
	190-255	Random Strobe
13		Dimmer Speed
	0-9	No Function
	10-29	Off
	30-69	Dim1
	70-129	Dim2
	130-189	Dim3
190-255	Dim4	

EXPOLITE

TR16		
1	0-255	Master Dimmer
2	0-255	Master Dimmer Fine
3	0-255	Red
4	0-255	Red Fine
5	0-255	Green
6	0-255	Green Fine
7	0-255	Blue
8	0-255	Blue Fine
9	0-255	Amber
10	0-255	Amber Fine
11	0-255	Lime
12	0-255	Lime Fine
13	0-255	Cyan
14	0-255	Cyan Fine
15		Preset Colours
	0-11	No Function
	11-20	L106
	21-30	R05
	31-40	L194
	41-50	R54
	51-60	L019
	61-70	R08
	71-80	R89
	81-90	R86
	91-100	L213
	101-110	R377
	111-120	R80
	121-130	L202
	131-140	L328
	141-150	R3314
151-160	L101	
161-170	L768	
171-255	No Function	
16		Colour Macro & White
	0-10	No Function
	11-30	Red 100% / Green Up / Blue 0%
	31-50	Red Down / Green 100% / Blue 0%
	51-70	Red 0% / Green 100% / Blue Up
	71-90	Red 0% / Green Down / Blue 100%
	91-110	Red Up / Green 0% / Blue 100%
	111-130	Red 100% / Green 0% / Blue Down
	131-150	Red 100% / Green Up / Blue Up
	151-170	Red Down / Green Down / Blue 100%
	171-195	All Led at Full Output

EXPOLITE

16	196-199	1800K
	200-203	2200K
	204-207	2700K
	208-211	3000K
	212-215	3200K
	216-219	3500K
	220-223	4000K
	224-227	4200K
	228-231	4500K
	232-235	5600K
	236-239	6000K
	240-243	6500K
	244-247	7200K
	248-255	8000K
17		Auto
	0 - 40	No Function
	41-50	Auto 1
	51-60	Auto 2
	61-70	Auto 3
	71-80	Auto 4
	81-90	Auto 5
	91-100	Auto 6
	101-110	Auto 7
	111-120	Auto 8
	121-130	Auto 9
	131-140	Auto 10
	141-150	Program 1
	151-160	Program 2
	161-170	Program 3
	171-180	Program 4
	181-190	Program 5
191-200	Program 6	
201-210	Program 7	
211-220	Program 8	
221-230	Program 9	
231-255	Program 10	
18	0-255	Auto Speed Adjustment
19		Strobe
	0-9	No Function
	10-99	Strobe (Slow to fast)
	100-109	No Function
	110-179	Lightning Strobe
	180-189	No Function
190-255	Random Strobe	

EXPOLITE

20		Dimmer Speed
	0-9	No Function
	10-29	Off
	30-69	Dim1
	70-129	Dim2
	130-189	Dim3
	190-255	Dim4



Delivery

- Expolite ProPAR X3 COB
- Power connection cable
- General Information for Expolite Units
- User Manual

Expolite devices are carefully checked before shipment. If the delivery is not complete, please contact your distributor immediately.

Product Information

Voltage	100V - 240V AC 50/60Hz
Power Consumption	145W
Dimensions	320 x 217 x 418mm
Weight	6,5kg
Connectors	Power In/Out DMX In/Out
Ambient Temperature	-20°C - 45°C
Humidity*	< 80%
Protection	IP 65
Housing	Die-cast aluminium housing
LEDs	1x 150W RGBACL
LED Current	1A
Optics	16°
Control	Stand-Alone / DMX512 / RDM
DMX-Channels	3 - 20 (3/6/7/10/13/20)

* take note to General Informations for Expolite Units - Notes for Condensation inside Housing.

ILLUMINANCE AT DISTANCE

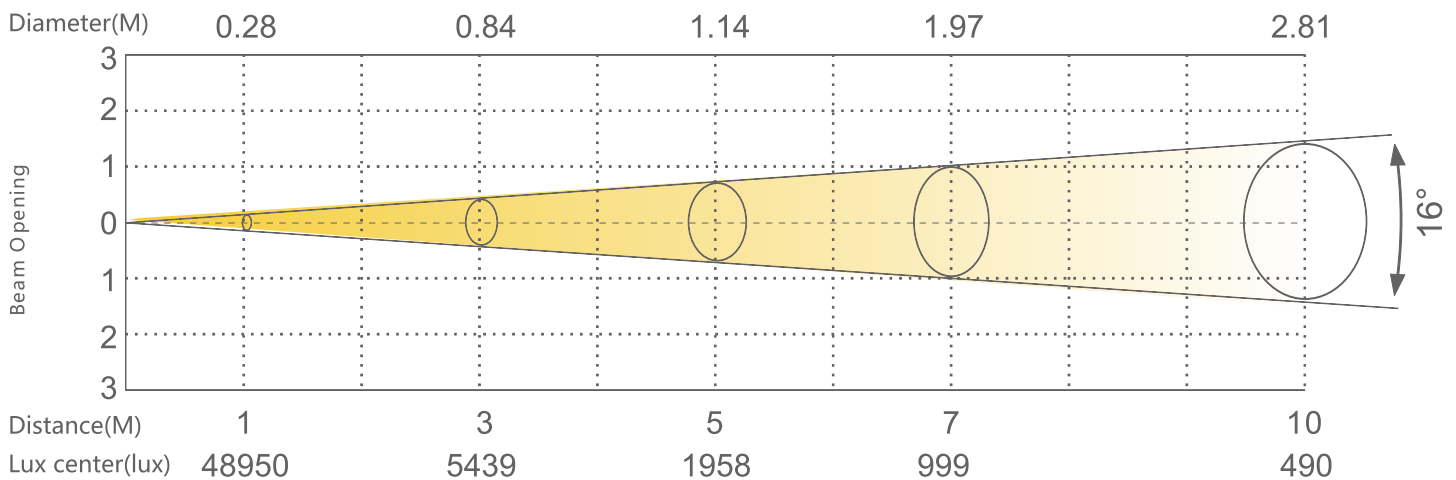

Dimensions

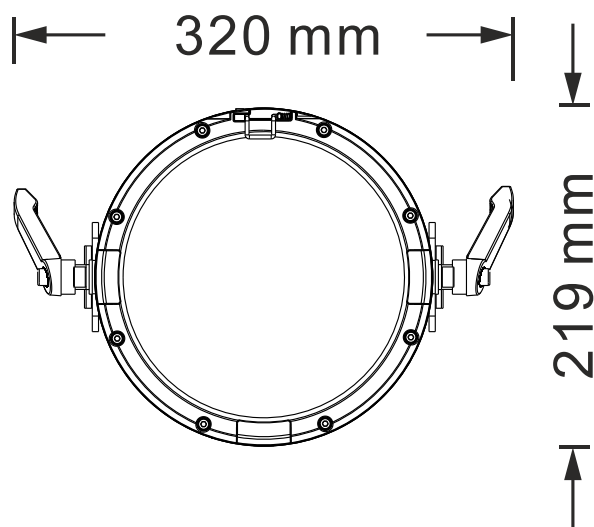
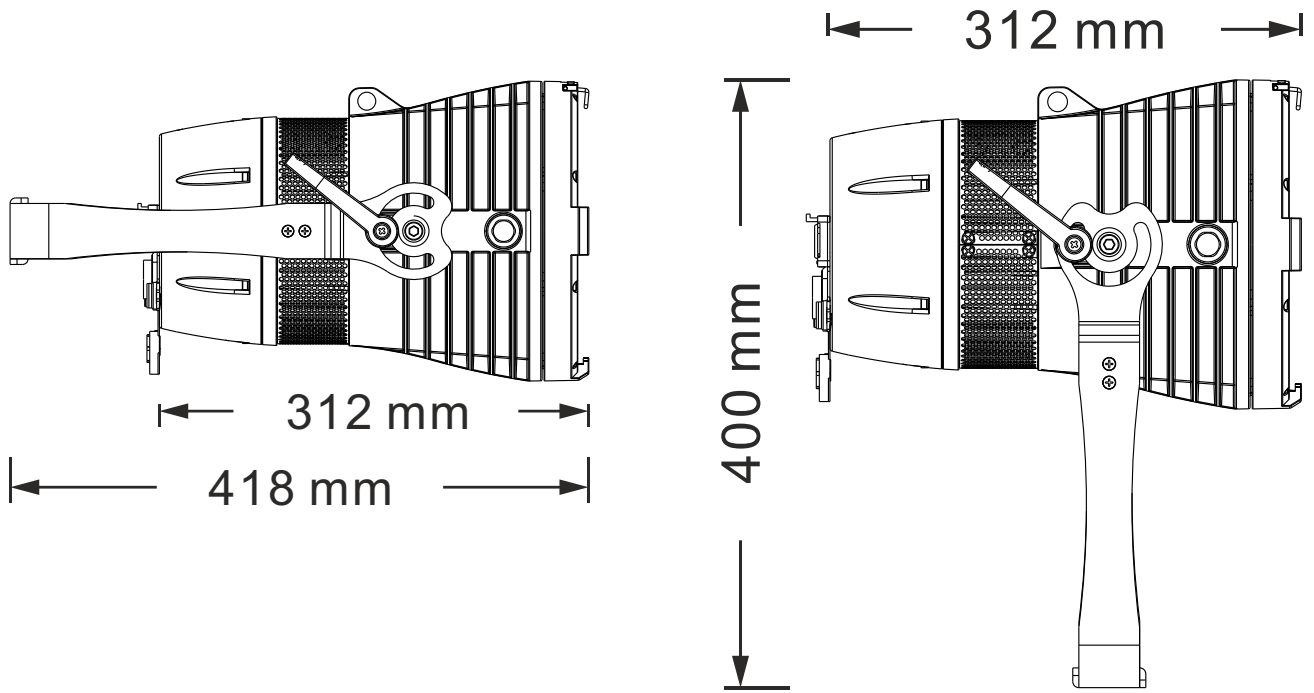

Installation

Mounting

Hanging

The device can be used in any position. On the mounting bracket are holes available, for attaching standard brackets. Fixture must be safe mounted in accordance with the relevant regulations and provided with a safety cord to prevent falling. For this purpose, an eyelet for safeties is attached to the device.

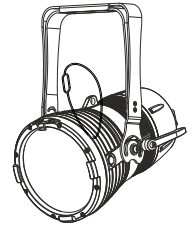

Standing

The device can be placed directly on the mounted bracket. For this purpose, it must be opened up to the mechanical stop.

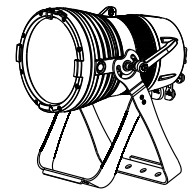

NOTE

The LED module can be operated in any position.

Powerconnection

230V: max. 12 fixtures in a row.

110V: max. 6 fixtures in a row.

DMX-Connection

Use specified DMX-cables to connect the units to each other and to connect them to the control-desk. Enter the addresses and personalities to the units.

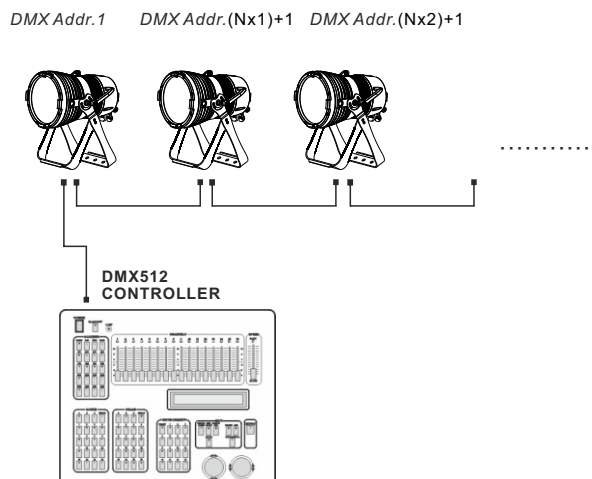

Operation

Display Operation

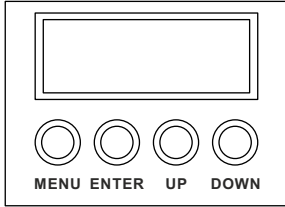

MENU:
ENTER:
UP:
DOWN:

Return to previous menu
Enter currently selected menu
Scroll Up, Increase value
Scroll down: Decrease value

Menu Map

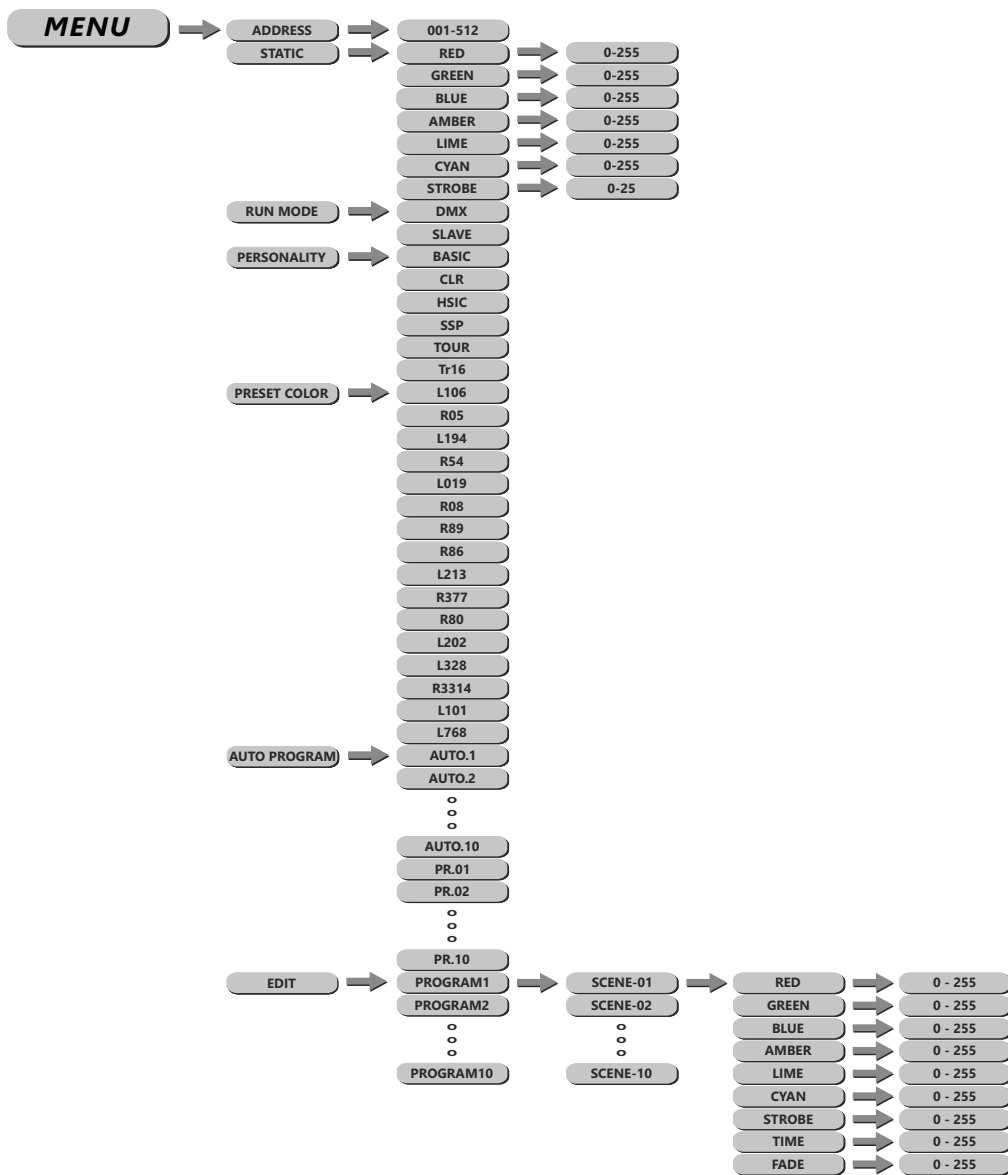

EXPOLITE

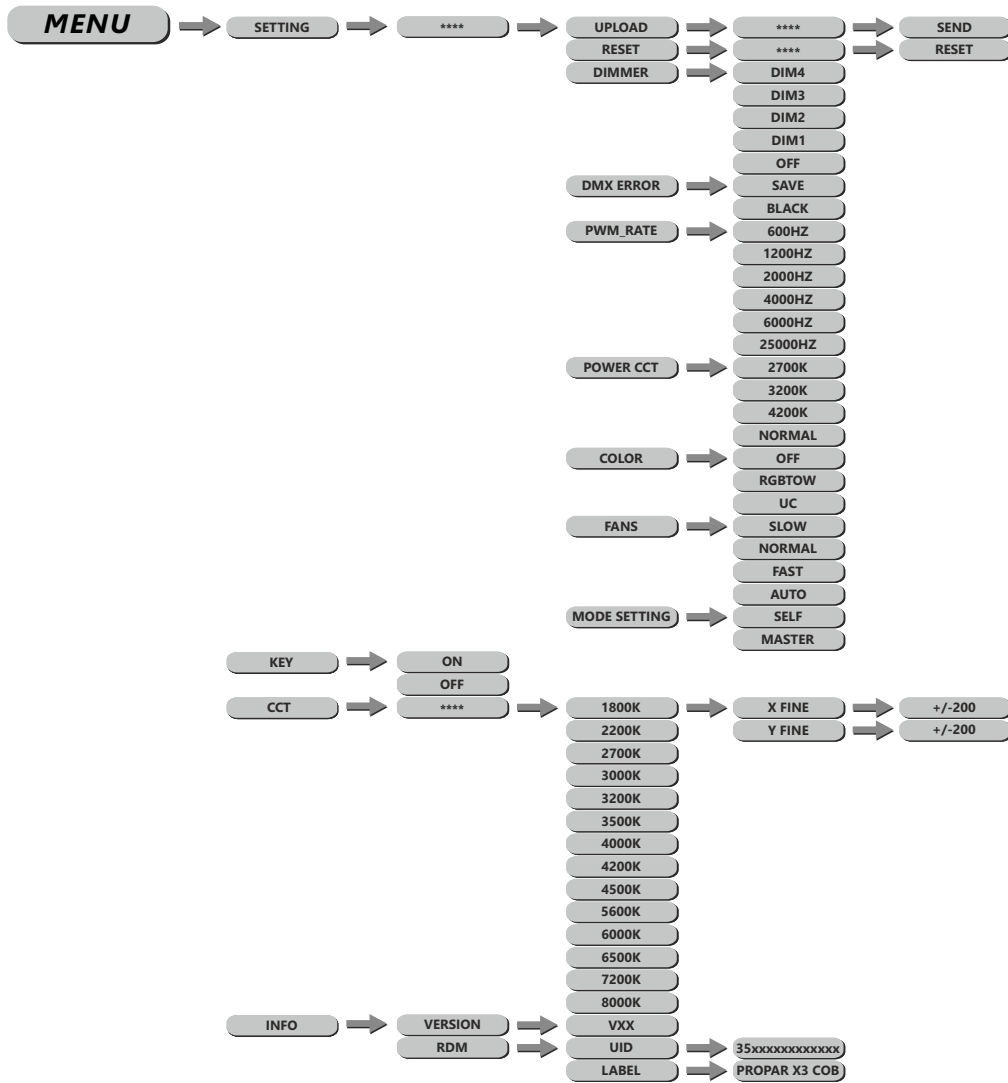

Setting DMX-Address



The DMX start address of the fixture is set in the menu **ADDRESS**. This is retained even when changing the personality.

Setting DMX-Personality

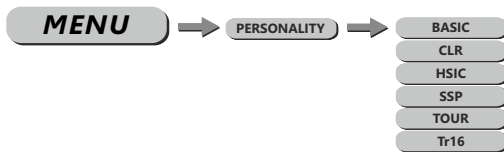

The personality is set in the menu **PERSONALITY**. There are six different modes which can be chosen: **BASIC** (3 channels), **CLR** (6 channels), **HSIC** (7 channels), **SSP** (10 channels), **TOUR** (13 channels) and **TR16** (20 channels).

Edit Static Colours

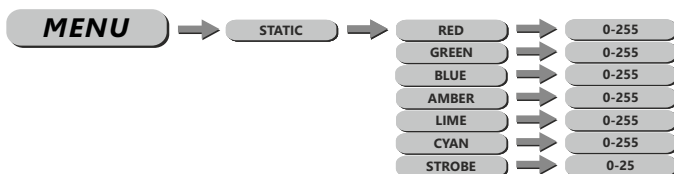

Static colours for stand-alone operation are set in **STATIC**. These are mixed using the DMX value scale 0-255 for **RED**, **GREEN**, **BLUE**, **AMBER**, **LIME** and **CYAN**, as well as the **STROBE** value 0-25Hz.

Preset Static Colours

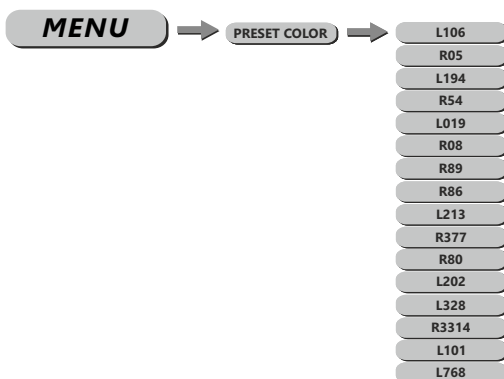

In the menu **PRESET COLOR** some preset RAL- (**R**) and LEE-colours (**L**) can be chosen.

Activating Auto Programs

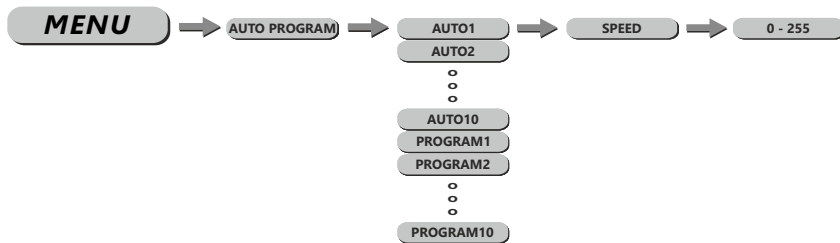

In the menu **AUTO PROGRAM** the automatic programs stored in the device are activated. The programs **AUTO1** to **AUTO10** are permanently stored in the device. The programs **PROGRAM1** to **PROGRAM10** are editable. This is described under **Edit User Programs**. Automatic programs are transmitted as master to connected slave devices. For master-slave operation, signals are sent via the DMX line. This may disturb other devices on the same line.

Choose Run Mode



The operating mode is set in menu **RUN MODE**. For operation on a DMX-controller **DMX** needs to be set. **SLAVE** sets the fixture into slave mode.

Edit User Programs

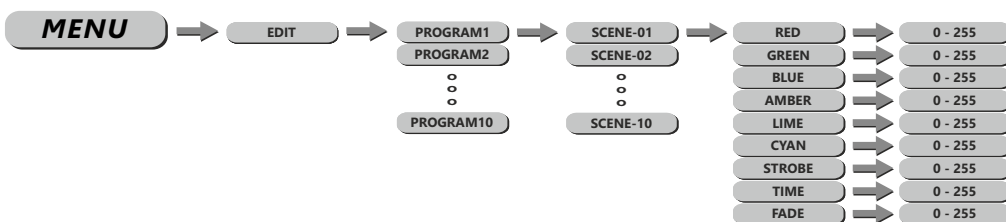

In the menu **EDIT** the user programs **PROGRAM1** to **PROGRAM10** can be edited.

Every program can have up to 10 steps (**SCENE-01** - **SCENE-10**). Every step persists of the parameter colours **RGBALC**, **STROBE** „0-20Hz“, **TIME** and **FADE**.

User programs can be transferred to other fixtures (see master/slave).

Step-by-step programming of the custom stand-alone programs with up to 10 different steps:

NOTE: For less than 10 steps the **TIME** and **FADE** of the last step needs to be set to 0.

Example for time settings of a stand-alone programm with 3 steps:

Step 1 **TIME** = 4 **FADE** = 3
 Step 2 **TIME** = 5 **FADE** = 2
 Step 3 **TIME** = 0 **FADE** = 0

Miscellaneous Settings

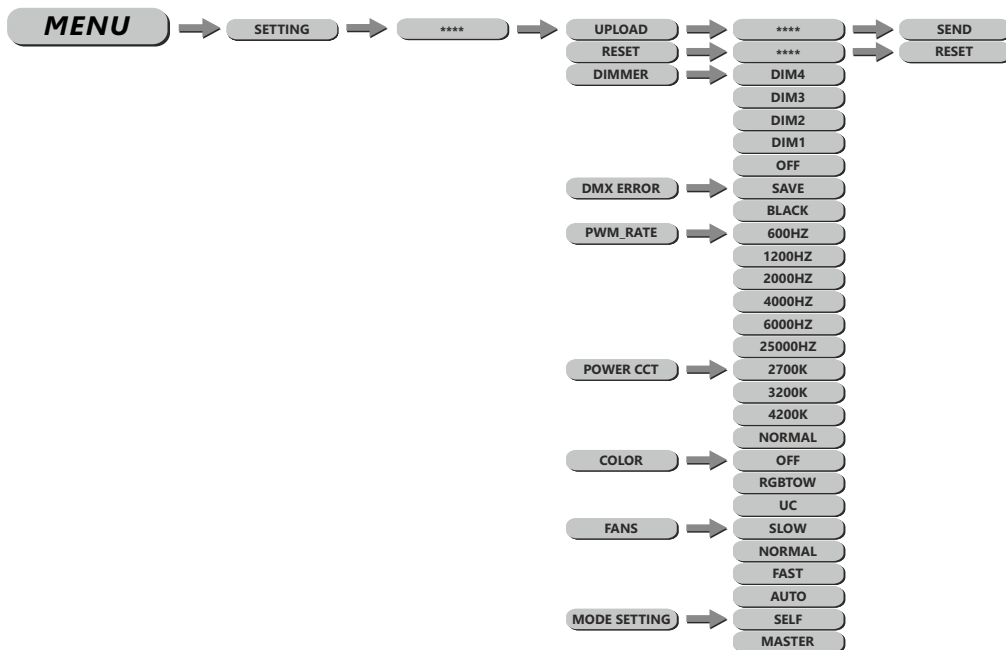

The default password is: **UP - DOWN - UP - DOWN - ENTER**

UPLOAD: sends the user programs to connected slave fixtures.

RESET: sets all editable settings back to factory default.

DIMMER: controls different dimming speeds to simulate a halogen bulb (**OFF/DIM1/DIM2/DIM3/DIM4**).

DMX ERROR: sets how the fixture responds if DMX-signal gets lost. Set **SAVE** to hold the last received value or **BLACK** for blackout.

PWM_RATE: gives the user the possibility to adjust the PWM frequency of the leds (**600HZ/1200HZ/2000HZ/4000HZ/6000HZ/25000HZ**).

FULL POWER CCT: sets the colour temperature at maximum output. **2700K/3200K/4200K** and **NORMAL** can be set.

COLOR: in this submenu a colour calibration is selected or deactivated. When **RGBTOW** is selected, the maximum brightness values at DMX = 255 are limited to the values set in **CCT\RGBTOW**. When **UC** is selected the Uniform-Colour factory calibration is used, which adjusts devices of different generations. If the value is set **OFF**, the calibration is deactivated and the device reaches the maximum brightness.

FANS: SLOW/NORMAL/FAST/AUTO regulates the fan performance balance.

MODE SETTING: sets whether the fixture is a master and sends data to other fixtures (**MASTER**), or not (**SELF**).

Activate Password Protection



In the menu **KEY** the password protection of the fixture is activated or deactivated. If set **ON** the fixture is password protected when started. 30 seconds after the last setting the menu is locked again. To be able to make changes in the menu the password **UP - DOWN - UP - DOWN - ENTER** needs to be typed in.

Calibration and Whiteadjustment

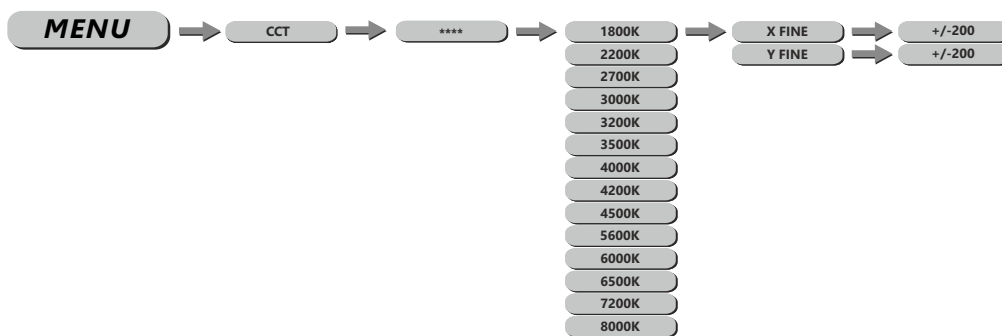

In the menu **CCT**, submenu **CCT** the preset colour temperatures for the white values are stored. These can be adjusted via **X FINE** and **Y FINE (+/-200)**.

Info Menu



In the info menu (**INFO**), submenu **VERSION** the currently installed firmware version is shown. In the submenu **RDM**, submenu **UID** the RMD-ID of the fixture and in the submenu **LABEL** the model name of the fixture can be found.

Using DMX512 Control

DMX-Channel assignment

This device has several DMX personalities. In each personality a different number of DMX channels is used and the reaction of the device differs accordingly. There are six DMX personalities with 3, 6, 7, 10, 13 and 20 channels selectable.

Because of changes in the firmware of the fixture, functions can be added or changed. You can find the current version „DMX-Channels“ as PDF-file on the website, ready to download.

BASIC		
1	0-255	Master Dimmer
2		Preset Colours
	0-11	No Function
	11-20	L106
	21-30	R05
	31-40	L194
	41-50	R54
	51-60	L019
	61-70	R08
	71-80	R89
	81-90	R86
	91-100	L213
	101-110	R377
	111-120	R80
	121-130	L202
	131-140	L328
	141-150	R3314
	151-160	L101
161-170	L768	
171-255	No Function	
3		Colour Macro & White
	0-10	No Function
	11-30	Red 100% / Green Up / Blue 0%
	31-50	Red Down / Green 100% / Blue 0%
	51-70	Red 0% / Green 100% / Blue Up
	71-90	Red 0% / Green Down / Blue 100%
	91-110	Red Up / Green 0% / Blue 100%
	111-130	Red 100% / Green 0% / Blue Down
	131-150	Red 100% / Green Up / Blue Up
	151-170	Red Down / Green Down / Blue 100%
	171-195	All Led at Full Output
	196-199	1800K
	200-203	2200K
	204-207	2700K
	208-211	3000K
212-215	3200K	

EXPOLITE

3	216-219	3500K
	220-223	4000K
	224-227	4200K
	228-231	4500K
	232-235	5600K
	236-239	6000K
	240-243	6500K
	244-247	7200K
	248-255	8000K

CLR		
1	0-255	Red
2	0-255	Green
3	0-255	Blue
4	0-255	Amber
5	0-255	Lime
6	0-255	Cyan

SSP		
1	0-255	Master Dimmer
2	0-255	Dimmer Fine
3	0-255	Red
4	0-255	Green
5	0-255	Blue
6	0-255	Amber
7	0-255	Lime
8	0-255	Cyan
9		Strobe
	0-9	No Function
	10-99	Strobe (Slow to fast)
	100-109	No Function
	110-179	Lightning Strobe
	180-189	No Function
190-255	Random Strobe	
10		Dimmer Speed
	0-9	No Function
	10-29	Off
	30-69	Dim1
	70-129	Dim2
	130-189	Dim3
190-255	Dim4	

EXPOLITE

HSIC		
1	0-255	Intensity
2	0-255	Hue
3	0-255	Hue Fine
4	0-255	Saturation
5		Colour Temperature
	0-10	No Function
	11-28	1800K
	29-46	2200K
	47-64	2700K
	65-82	3000K
	83-100	3200K
	101-118	3500K
	119-136	4000K
	137-154	4200K
	155-172	4500K
	173-190	5600K
	191-208	6000K
	209-226	6500K
	227-244	7200K
245-255	8000K	
6		Strobe
	0-9	No Function
	10-99	Strobe (Slow to fast)
	100-109	No Function
	110-179	Lightning Strobe
	180-189	No Function
190-255	Random Strobe	
7		Dimmer Speed
	0-9	No Function
	10-29	Off
	30-69	Dim1
	70-129	Dim2
	130-189	Dim3
190-255	Dim4	

EXPOLITE

TOUR		
1	0-255	Master Dimmer
2	0-255	Red
3	0-255	Green
4	0-255	Blue
5	0-255	Amber
6	0-255	Lime
7	0-255	Cyan
8		Preset Colours
	0-11	No Function
	11-20	L106
	21-30	R05
	31-40	L194
	41-50	R54
	51-60	L019
	61-70	R08
	71-80	R89
	81-90	R86
	91-100	L213
	101-110	R377
	111-120	R80
	121-130	L202
	131-140	L328
	141-150	R3314
151-160	L101	
161-170	L768	
171-255	No Function	
9		Colour Macro & White
	0-10	No Function
	11-30	Red 100% / Green Up / Blue 0%
	31-50	Red Down / Green 100% / Blue 0%
	51-70	Red 0% / Green 100% / Blue Up
	71-90	Red 0% / Green Down / Blue 100%
	91-110	Red Up / Green 0% / Blue 100%
	111-130	Red 100% / Green 0% / Blue Down
	131-150	Red 100% / Green Up / Blue Up
	151-170	Red Down / Green Down / Blue 100%
	171-195	All Led at Full Output
	196-199	1800K
	200-203	2200K
	204-207	2700K
	208-211	3000K
	212-215	3200K
216-219	3500K	

EXPOLITE

9	220-223	4000K
	224-227	4200K
	228-231	4500K
	232-235	5600K
	236-239	6000K
	240-243	6500K
	244-247	7200K
	248-255	8000K
10		Auto
	0 - 40	No Function
	41-50	Auto 1
	51-60	Auto 2
	61-70	Auto 3
	71-80	Auto 4
	81-90	Auto 5
	91-100	Auto 6
	101-110	Auto 7
	111-120	Auto 8
	121-130	Auto 9
	131-140	Auto 10
	141-150	Program 1
	151-160	Program 2
	161-170	Program 3
	171-180	Program 4
	181-190	Program 5
	191-200	Program 6
201-210	Program 7	
211-220	Program 8	
221-230	Program 9	
231-255	Program 10	
11	0-255	Auto Speed Adjustment
12		Strobe
	0-9	No Function
	10-99	Strobe (Slow to fast)
	100-109	No Function
	110-179	Lightning Strobe
	180-189	No Function
	190-255	Random Strobe
13		Dimmer Speed
	0-9	No Function
	10-29	Off
	30-69	Dim1
	70-129	Dim2
	130-189	Dim3
190-255	Dim4	

EXPOLITE

TR16		
1	0-255	Master Dimmer
2	0-255	Master Dimmer Fine
3	0-255	Red
4	0-255	Red Fine
5	0-255	Green
6	0-255	Green Fine
7	0-255	Blue
8	0-255	Blue Fine
9	0-255	Amber
10	0-255	Amber Fine
11	0-255	Lime
12	0-255	Lime Fine
13	0-255	Cyan
14	0-255	Cyan Fine
15		Preset Colours
	0-11	No Function
	11-20	L106
	21-30	R05
	31-40	L194
	41-50	R54
	51-60	L019
	61-70	R08
	71-80	R89
	81-90	R86
	91-100	L213
	101-110	R377
	111-120	R80
	121-130	L202
	131-140	L328
	141-150	R3314
151-160	L101	
161-170	L768	
171-255	No Function	
16		Colour Macro & White
	0-10	No Function
	11-30	Red 100% / Green Up / Blue 0%
	31-50	Red Down / Green 100% / Blue 0%
	51-70	Red 0% / Green 100% / Blue Up
	71-90	Red 0% / Green Down / Blue 100%
	91-110	Red Up / Green 0% / Blue 100%
	111-130	Red 100% / Green 0% / Blue Down
	131-150	Red 100% / Green Up / Blue Up
	151-170	Red Down / Green Down / Blue 100%
	171-195	All Led at Full Output

EXPOLITE

16	196-199	1800K
	200-203	2200K
	204-207	2700K
	208-211	3000K
	212-215	3200K
	216-219	3500K
	220-223	4000K
	224-227	4200K
	228-231	4500K
	232-235	5600K
	236-239	6000K
	240-243	6500K
	244-247	7200K
	248-255	8000K
17		Auto
	0 - 40	No Function
	41-50	Auto 1
	51-60	Auto 2
	61-70	Auto 3
	71-80	Auto 4
	81-90	Auto 5
	91-100	Auto 6
	101-110	Auto 7
	111-120	Auto 8
	121-130	Auto 9
	131-140	Auto 10
	141-150	Program 1
	151-160	Program 2
	161-170	Program 3
	171-180	Program 4
	181-190	Program 5
	191-200	Program 6
201-210	Program 7	
211-220	Program 8	
221-230	Program 9	
231-255	Program 10	
18	0-255	Auto Speed Adjustment
19		Strobe
	0-9	No Function
	10-99	Strobe (Slow to fast)
	100-109	No Function
	110-179	Lightning Strobe
	180-189	No Function
190-255	Random Strobe	

EXPOLITE

20		Dimmer Speed
	0-9	No Function
	10-29	Off
	30-69	Dim1
	70-129	Dim2
	130-189	Dim3
	190-255	Dim4

EXPOLITE

CE RoHS