



# SLXD4Q+

## Wireless System

Shure SLXD4Q+ wireless system guide. Includes how to set up receiver, networking information, specifications, and more.  
Version: 1.2 (2025-L)

# Table of Contents

<b>SLXD4Q+ Wireless System</b>	<b>4</b>	<b>Radio Frequency (RF) Settings</b>	<b>24</b>
<b>SLXD4Q+ Overview</b>	<b>4</b>	How to Use Narrowband Transmitters with a Wideband Receiver	24
Features	4	Setting the Transmitter RF Power	24
<b>SLXD4Q+ Receiver</b>	<b>4</b>	RF Cascade Ports	24
SLXD4Q+ Hardware Callouts	5	Antenna Bias	24
SLXD4Q+ Setup	7	<b>Connecting to a Network</b>	<b>24</b>
SLXD4Q+ Menu	8	Network Controllers	25
Locking and Unlocking the Receiver	10	IP Address Configuration	25
<b>SLX-D Transmitters</b>	<b>10</b>	Dante Switch Modes	26
Transmitters	11	Network Troubleshooting	27
Transmitter Menu	14	<b>How to Update Firmware</b>	<b>27</b>
Locking and Unlocking Transmitters	15	Updating the Transmitter Firmware	27
<b>Batteries and Chargers</b>	<b>15</b>	Firmware Version Requirements	27
Microphone Battery Installation	15	<b>Rack Mounting the Receiver</b>	<b>27</b>
Setting the AA Battery Type	17	Installing Footpads	28
Shure SB903 Rechargeable Battery	17	<b>Optional Accessories</b>	<b>28</b>
Important Tips for Care and Storage of Shure Rechargeable Batteries	20	<b>Specifications</b>	<b>33</b>
Average Charging Times	20	Receiver Output Connectors	41
<b>How to Link SLX-D Transmitters and Receivers</b>	<b>20</b>	Transmitter Input	42
Creating Audio Channels	20	<b>Frequency Range and Transmitter Output Power</b>	<b>42</b>
What are Groups and Channels?	21	Frequencies for European Countries	43
Group and Channel Scan	21	<b>Safety and Regulatory Information for Wireless Products</b>	<b>43</b>
Manual Frequency Selection	21	Explanation of Symbols	43
Using the Guided Frequency Setup	22	Important Safety Instructions	44
Linking Two Transmitters to a Receiver	22	<b>Safety and Regulatory Information for Battery Chargers</b>	<b>44</b>
<b>Gain Adjustment</b>	<b>23</b>	4	
<b>Audio Summing</b>	<b>23</b>	<b>Safety Information for Batteries</b>	<b>45</b>

---

Storing Batteries	45	Battery Regulatory Information	51
<b>Important Product Regulatory Information</b>	<b>46</b>	<b>Certifications</b>	<b>51</b>
Regulatory Information for Class B EMC Products	46	Regulatory Model Number (RMN)	52
Regulatory Information for Wireless Products	48	FCC / IC ID	52
Environmental Regulatory Information	51	Energy Efficiency	52

---

# SLXD4Q+ Wireless System

---

## SLXD4Q+ Overview

The SLXD4Q+ wireless system delivers clear audio and stable RF performance with easy setup and rechargeability options. This wireless system is built to handle a wide range of applications, from day-long conferences to nighttime performances. The quad receiver is available in both standard and Dante versions. Wideband receivers comply with regional broadcast regulations and are compatible with existing regional SLX-D transmitter tuning ranges.

Automatic RF scan and IR sync are even easier with a guided setup feature programmed into each wireless receiver. Manage multiple-system group scans and firmware updates with third-party setup and control via Ethernet. Set and combine audio levels using the audio summing feature. Create an 8-channel receiver system with RF cascade ports. Receivers operate over 138 MHz wideband range, or 44 MHz when used with narrowband transmitters. Transmitters run up to 8 hours using 2 AA batteries, or add Shure SB903 rechargeable batteries and charger accessories. SLXD4Q+ provides >118 dB dynamic range and stable, efficient RF transmission for a selection of handheld, lavalier and headset microphones.

## Features

- Transparent 24-bit digital audio
- Extended 20 Hz to 20 kHz frequency range (microphone dependent)
- 118 dB dynamic range
- 138 MHz wideband range
- 32 available channels per 44 MHz narrowband (region dependent)
- Compatible with Shure Wireless Workbench® control software
- Third-party setup and control via Ethernet
- Dante connectivity (receiver model dependent)
- RF cascade and bias voltage
- Audio summing available on all outputs

## System Components

Your SLX-D system is available in multiple configurations of transmitters, receivers, and microphones to meet your specific needs. For a full list of available system configurations, [visit shure.com](https://www.shure.com) or contact your local sales rep.

---

## SLXD4Q+ Receiver

①

Rack mounting hardware

②

¼-wave antennas (2)

③

PS60 power supply

④

Ethernet cable

⑤

SLXD4Q+ receiver

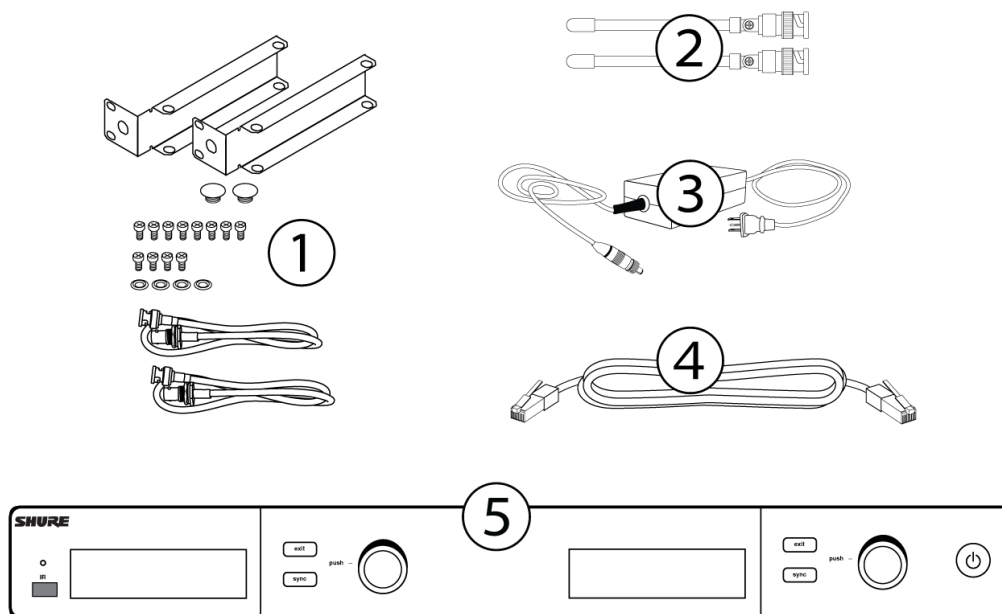

## SLXD4Q+ Hardware Callouts

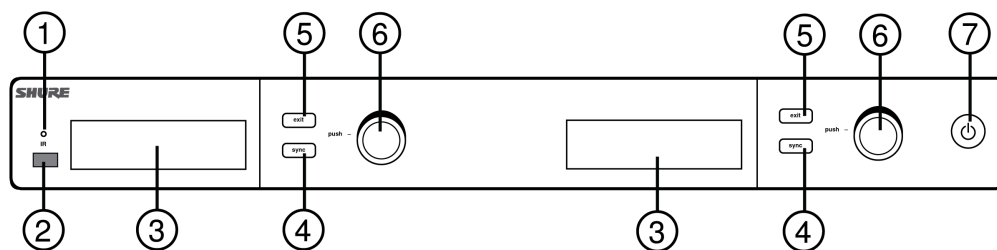

### ① Sync LED

- Flashing = IR sync mode is enabled
- Solid = receiver and transmitter aligned for IR sync

### ② IR port

Align with the transmitter IR port during an IR sync to program transmitters.

### ③ Display

Shows menu options, receiver settings, and transmitter settings.

#### ④ Sync button

Press to activate IR sync.

#### ⑤ Exit button

Press to cancel and exit the current operation.

#### ⑥ Control knob

Change menu parameters. Push knob to confirm changes.

#### ⑦ Power button

Powers receiver on or off.

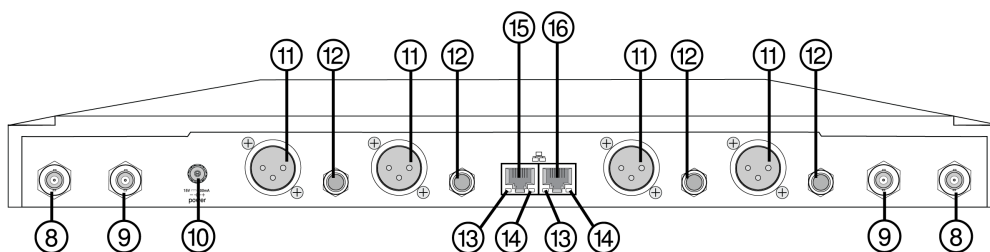

#### ⑧ Antenna connectors

BNC connector for receiver antennas.

#### ⑨ RF cascade port

Passes the RF signal from Antenna A and Antenna B to one additional receiver.

#### ⑩ Power supply port

Connection point for DC power supply.

#### ⑪ XLR audio output

Balanced (1: ground, 2: audio +, 3: audio -)

#### ⑫ 1/4" instrument/auxiliary output

Impedance Balanced (Tip: audio+, Ring: audio-, Sleeve: ground)

#### ⑬ Network speed LED (amber)

One per network port.

- Off = 10/100 Mbps
- On = 1 Gbps

#### ⑭ Network status LED (green)

One per network port.

- Off = no network link
- On = network link active
- Flashing = rate corresponds to traffic volume

### 15 Ethernet/Dante network secondary port

Connect to an Ethernet network to enable remote device control via Wireless Workbench software. Dante receivers carry Dante digital audio and control signals for audio distribution, monitoring, and recording.

### 16 Ethernet/Dante network primary port

Connect to an Ethernet network to enable remote device control via Wireless Workbench software. Dante receivers carry Dante digital audio and control signals for audio distribution, monitoring, and recording.

## SLXD4Q+ Setup

1. Attach the included antennas to the back of the receiver.\*

**Note:** Use the RF outputs to cascade the signal when using an additional SLX-D receiver.

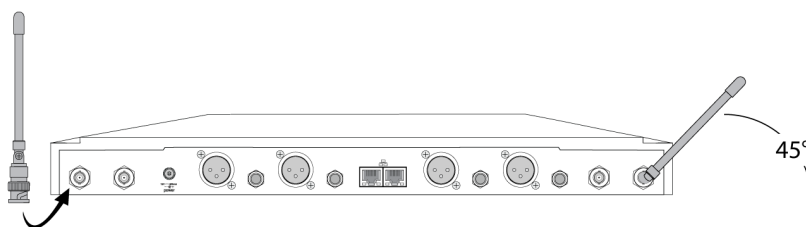

2. Connect the power supply to the receiver and plug the cord into an AC power source.

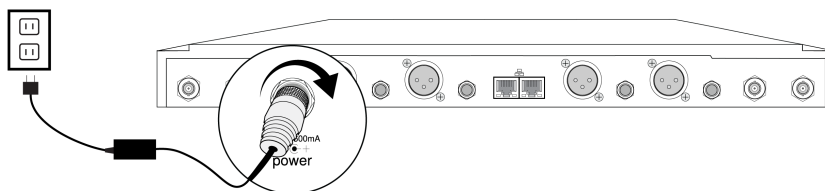

3. Connect the audio output to an amplifier or mixer.

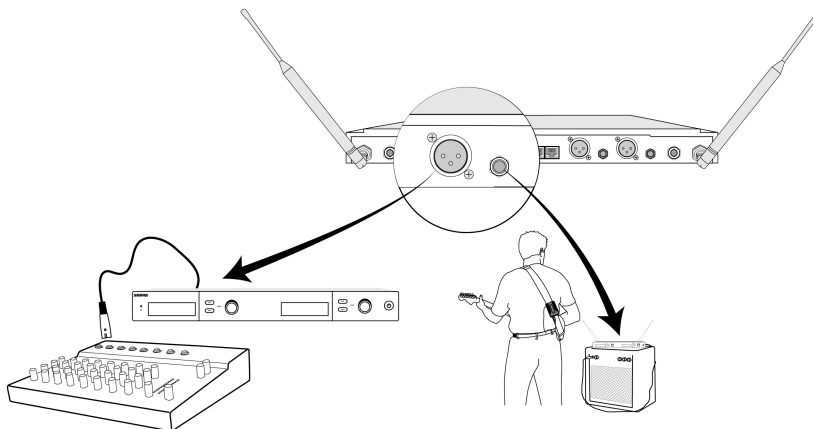

4. Press the power button on the receiver. Use the menu to set the system to microphone (mic) or instrument (line) level as appropriate.

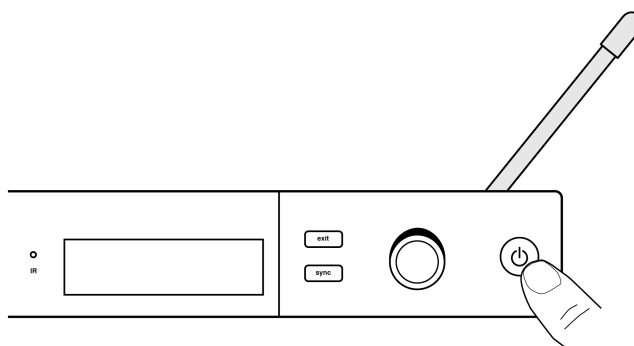

\*To use external active antennas, go to Device Configuration > RF > Antenna Bias > On.

## SLXD4Q+ Menu

Push the control knob to access the menu, and rotate to advance to the next menu screen.

<b>Frequency Setup</b>	<b>Guided Setup</b>	Step-by-step instructions to initialize a new system, or to add a receiver to an existing system
	<b>Group Scan</b>	Receiver automatically scans for the best available group, if applicable <b>Note:</b> Some bands consist of only a single group. RF performance is the same in single-group bands as in bands that support multiple groups.
	<b>Channel Scan</b>	Receiver automatically scans for available channels within the selected group

	<table border="1"> <tr> <td><b>Manual Frequency Setup</b></td> <td>Manually tune the receiver to a desired frequency</td> </tr> </table>	<b>Manual Frequency Setup</b>	Manually tune the receiver to a desired frequency						
<b>Manual Frequency Setup</b>	Manually tune the receiver to a desired frequency								
<b>Channel Name</b>	Customize the channel name								
<b>Audio Settings</b>	<table border="1"> <tr> <td><b>Gain</b></td> <td>Monitor audio levels and adjust the receiver gain</td> </tr> <tr> <td><b>Mic/Line Level</b></td> <td>Switch between output levels</td> </tr> </table>	<b>Gain</b>	Monitor audio levels and adjust the receiver gain	<b>Mic/Line Level</b>	Switch between output levels				
<b>Gain</b>	Monitor audio levels and adjust the receiver gain								
<b>Mic/Line Level</b>	Switch between output levels								
<b>Advanced</b>	<table border="1"> <tr> <td><b>Transmitter Preset</b></td> <td>Apply and sync transmitter presets</td> </tr> <tr> <td><b>Tx Factory Reset</b></td> <td>Restore transmitter settings to factory default following a system reboot</td> </tr> </table>	<b>Transmitter Preset</b>	Apply and sync transmitter presets	<b>Tx Factory Reset</b>	Restore transmitter settings to factory default following a system reboot				
<b>Transmitter Preset</b>	Apply and sync transmitter presets								
<b>Tx Factory Reset</b>	Restore transmitter settings to factory default following a system reboot								
<b>Device Configuration</b>	<table border="1"> <tr> <td><b>Audio</b></td> <td> <ul style="list-style-type: none"> <li>• Audio Summing: Choose an audio summing mode</li> </ul> </td> </tr> <tr> <td><b>RF</b></td> <td> <ul style="list-style-type: none"> <li>• Antenna Bias: Turn antenna bias on or off</li> <li>• RF Band: Change receiver band to match transmitter band</li> </ul> </td> </tr> <tr> <td><b>Dante*</b></td> <td> <ul style="list-style-type: none"> <li>• Dante Device Name: View and edit names for networked Dante components</li> <li>• Dante Device Lock: Displays status of Dante device lock</li> <li>• Dante Domain Manager: Displays status of Dante Domain Manager settings</li> </ul> <p>*Dante receivers only</p> </td> </tr> <tr> <td><b>Device Settings</b></td> <td> <ul style="list-style-type: none"> <li>• Device Lock: Lock or unlock receiver settings</li> <li>• Home Page View: Change information shown on display</li> <li>• Device Preset: Save current receiver settings or restore last saved settings</li> <li>• Controller Access: Block or allow third-party control access</li> </ul> </td> </tr> </table>	<b>Audio</b>	<ul style="list-style-type: none"> <li>• Audio Summing: Choose an audio summing mode</li> </ul>	<b>RF</b>	<ul style="list-style-type: none"> <li>• Antenna Bias: Turn antenna bias on or off</li> <li>• RF Band: Change receiver band to match transmitter band</li> </ul>	<b>Dante*</b>	<ul style="list-style-type: none"> <li>• Dante Device Name: View and edit names for networked Dante components</li> <li>• Dante Device Lock: Displays status of Dante device lock</li> <li>• Dante Domain Manager: Displays status of Dante Domain Manager settings</li> </ul> <p>*Dante receivers only</p>	<b>Device Settings</b>	<ul style="list-style-type: none"> <li>• Device Lock: Lock or unlock receiver settings</li> <li>• Home Page View: Change information shown on display</li> <li>• Device Preset: Save current receiver settings or restore last saved settings</li> <li>• Controller Access: Block or allow third-party control access</li> </ul>
<b>Audio</b>	<ul style="list-style-type: none"> <li>• Audio Summing: Choose an audio summing mode</li> </ul>								
<b>RF</b>	<ul style="list-style-type: none"> <li>• Antenna Bias: Turn antenna bias on or off</li> <li>• RF Band: Change receiver band to match transmitter band</li> </ul>								
<b>Dante*</b>	<ul style="list-style-type: none"> <li>• Dante Device Name: View and edit names for networked Dante components</li> <li>• Dante Device Lock: Displays status of Dante device lock</li> <li>• Dante Domain Manager: Displays status of Dante Domain Manager settings</li> </ul> <p>*Dante receivers only</p>								
<b>Device Settings</b>	<ul style="list-style-type: none"> <li>• Device Lock: Lock or unlock receiver settings</li> <li>• Home Page View: Change information shown on display</li> <li>• Device Preset: Save current receiver settings or restore last saved settings</li> <li>• Controller Access: Block or allow third-party control access</li> </ul>								

	<b>Connectivity</b>	<ul style="list-style-type: none"> <li>• Network Setup: Configure IP, network, and Dante settings</li> </ul>
	<b>Advanced Settings</b>	<ul style="list-style-type: none"> <li>• Transmitter Firmware: Update transmitter firmware using IR sync</li> <li>• Factory Reset: Restore all settings to factory default following a system reboot</li> </ul>
	<b>About</b>	Displays firmware version and serial number
<b>Help</b>	Provides a link to additional help materials	

## Locking and Unlocking the Receiver

The following control lock options can be accessed under [Device Configuration > Device Settings > Device Lock](#):

- Unlock: receiver controls are unlocked
- Lock Menu: prevents access to menu items (receiver can still be powered off)
- Lock Menu & Power: disables the power switch as well as menu controls

Select the desired option and press the control knob to confirm.

## SLX-D Transmitters

①

SLXD1 bodypack (BP) transmitter

②

SLXD2 handheld (HH) transmitter

③

SLXD3 plug-on (PO) transmitter

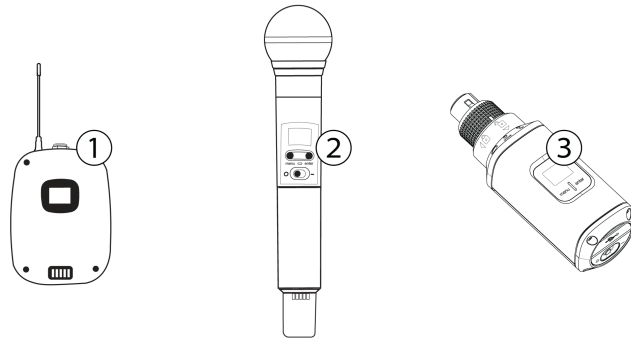

## Transmitters

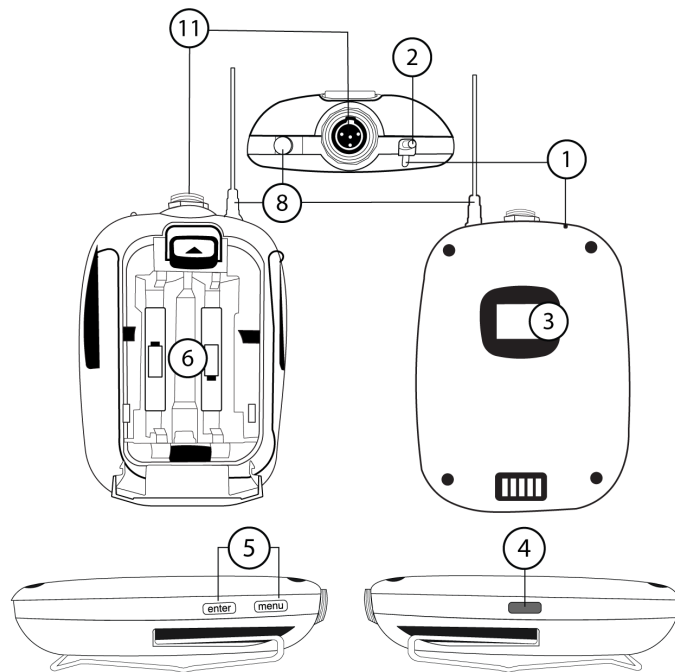

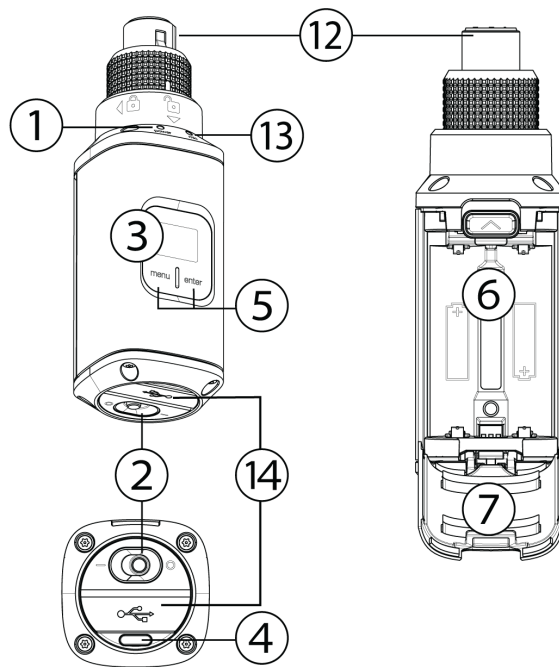
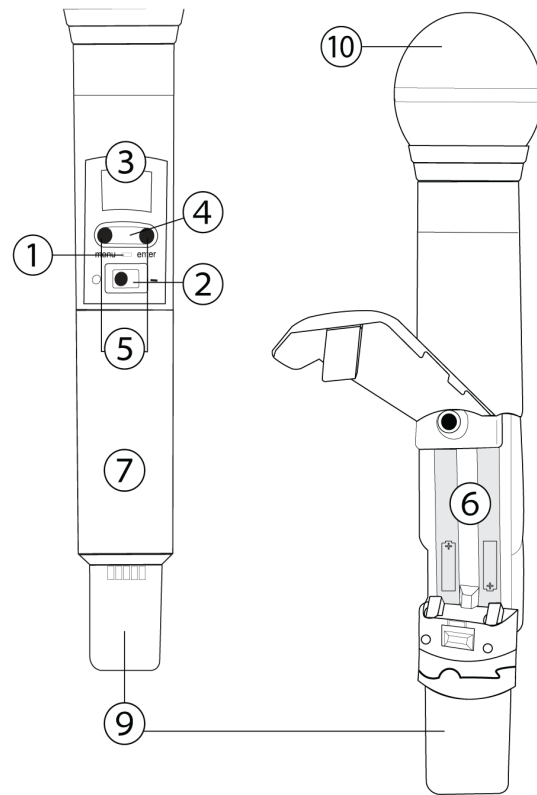

**① Power LED**

- Green = unit is powered on
- Red = low battery

---

## ② On/off switch

Powers the transmitter on or off.

## ③ Display

View menu screens and settings. Press any control button to activate the display.

## ④ IR port

Align with the receiver IR port during an IR sync for automated transmitter programming.

## ⑤ Menu navigation buttons

menu = use to navigate between menu screens.

enter = press to confirm and save parameter changes.

## ⑥ Battery compartment

Requires 2 AA batteries or a Shure SB903 rechargeable battery.

## ⑦ Battery cover

Protects battery compartment during use.

## ⑧ Bodypack antenna

For RF signal transmission.

## ⑨ Handheld integrated antenna

For RF signal transmission.

## ⑩ Microphone cartridge

Interchangeable with a variety of Shure cartridges.

## ⑪ TA4M input port

Connects to a 4-Pin Mini Connector (TA4F) microphone or instrument cable.

## ⑫ Locking XLR connector

Connection point for wired microphones, cables, boom poles, etc. To release the XLR connector, turn the ring counterclockwise and push in.

## ⑬ Microphone LED

Indicates audio input from connected microphone, regardless of receiver status.

## ⑭ USB-C port

Connect USB-C cable to power on or charge transmitter.

## Transmitter Menu

The transmitter features individual menu screens for setting up and adjusting the transmitter. To access the menu options from the home screen, press the menu button. Each additional press of the menu button advances to the next menu screen. Use the enter button to select and confirm options on the active menu screen.

<b>Home Screen</b>	<p>Use the enter button to select one of the following home screen displays:</p> <ul style="list-style-type: none"> <li>• Channel name/Group and channel/Battery icon</li> <li>• Channel name/Frequency/Battery icon</li> <li>• Channel name/Battery icon/Group and channel</li> <li>• Channel name/Battery icon</li> </ul>
<b>Mic Offset</b>	<p>Match audio levels between two transmitters used in a combo system. Range is 0 to 21 dB (3 dB increments)</p>
<b>RF Power</b>	<p>Select an RF power setting:</p> <ul style="list-style-type: none"> <li>• 1 mW</li> <li>• 10 mW</li> <li>• 30 mW*</li> </ul> <p>*SLXD3 only</p>
<b>High Pass</b>	<p>Turn the high pass filter on or off</p>
<b>Battery</b>	<p>To ensure accurate battery metering, set the battery type to match the installed AA battery type</p> <p><b>Note:</b> Menu is not selectable when Shure rechargeable batteries are installed</p>
<b>Auto Lock</b>	<p>Turn the transmitter auto lock on or off</p>
<b>Lock Type</b>	<p>Determine auto lock behavior:</p> <ul style="list-style-type: none"> <li>• Menu Only: Locks the menu to prevent transmitter settings from being changed</li> <li>• Menu &amp; Power: Locks the menu and disables the power switch</li> </ul>
<b>Phantom Power*</b>	<p>Select a phantom power setting:</p> <ul style="list-style-type: none"> <li>• Off (default setting)</li> <li>• +12 V</li> <li>• +48 V</li> </ul> <p>*SLXD3 only</p>

<b>Pad/Boost*</b>	<p>Select input pad or boost to avoid overloading the audio input, or increase low-output audio sources:</p> <ul style="list-style-type: none"> <li>• Off (default setting)</li> <li>• Pad: -12 dB</li> <li>• Boost: +12 dB</li> </ul> <p>*SLXD3 only</p>
<b>About</b>	Displays the firmware, hardware, and band information

## Locking and Unlocking Transmitters

### To activate auto lock:

1. Press the menu button to navigate to the Auto Lock settings.
2. Use the enter button to edit and the menu button to select On.
3. Press enter to save. The lock icon appears on the display to confirm that the control locks are enabled.

### To unlock the transmitter and deactivate auto lock:

1. Press enter then menu to unlock the transmitter controls.
2. Navigate to the Auto Lock settings and select Off.
3. Press enter to save. The transmitter will no longer lock when you return to the home screen.

## Batteries and Chargers

### Microphone Battery Installation

**Important:** To avoid damaging transmitters, only use Shure SB903 Li-ion rechargeable batteries or 1.5V AA batteries.

#### Bodypack / Plug-On:

1. Push the tab up and open the battery door to access the battery compartment.
2. Place a Shure SB903 Li-ion rechargeable battery or 2 AA batteries in the compartment.
3. Close the battery door.

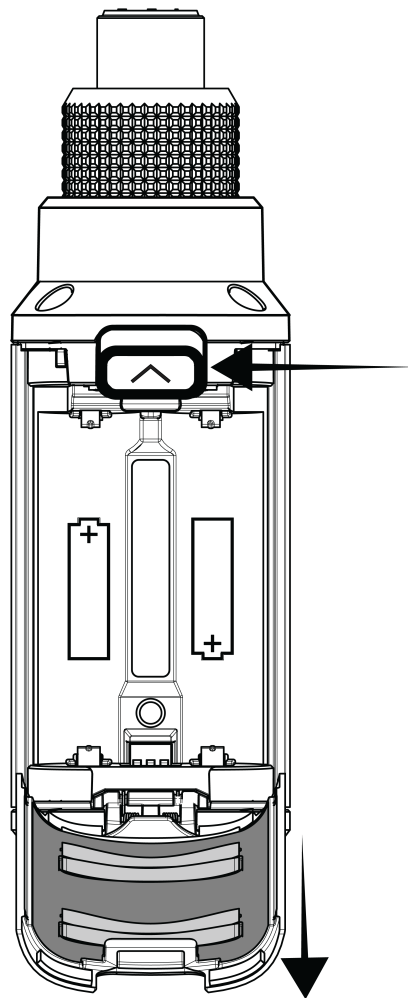
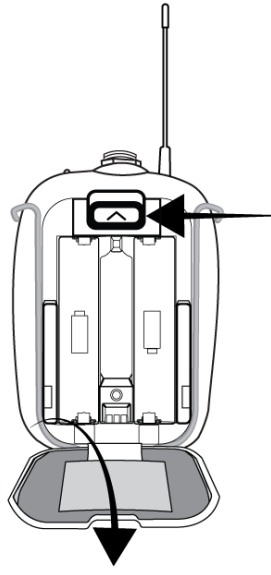

**Handheld:**

1. Remove the battery cover to access the battery compartment.
2. Lift the battery door to open the battery compartment.
3. Place a Shure SB903 Li-ion rechargeable battery or 2 AA batteries in the compartment.
4. Replace the battery cover.

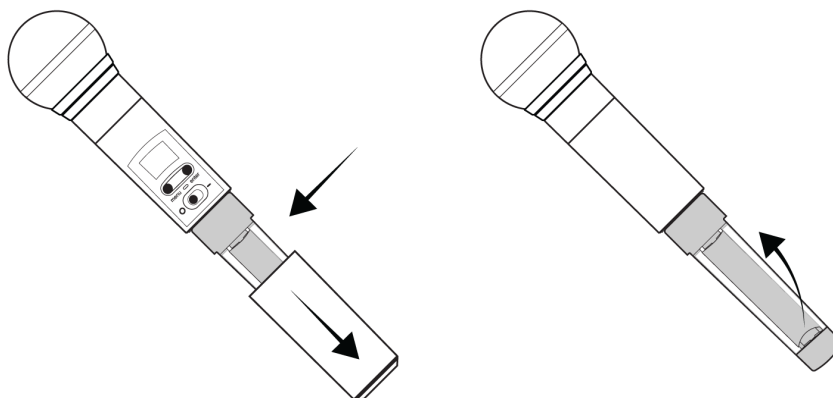

## Setting the AA Battery Type

To ensure accurate display of transmitter runtime, set the battery type in the transmitter menu to match the installed AA battery type. If a Shure rechargeable battery is installed, selecting a battery type is not necessary and the battery type menu will not be displayed.

1. Press the menu button to navigate to the Battery screen.
2. Press enter, then use the menu button to select the installed battery type:
  - Alkaline (default setting)
  - NiMH (nickel metal hydride)
  - Lithium (non-rechargeable, 1.5V max)
3. Press enter to save.

## Shure SB903 Rechargeable Battery

The SB903 lithium-ion rechargeable battery powers the SLX-D transmitters. Use the SBC10-903 single bay or SBC203 dual bay chargers to recharge SB903 batteries.

**Important:** Always fully charge a new battery before first use.

To fully charge a new SB903 battery, it must be placed directly in the charger. After the first charge, the battery can be charged by docking the transmitter in the SBC203 dual-bay charging station.

### Single Bay Charger

The SBC10-903 single bay charger offers a compact charging solution.

1. Plug the charger into an AC power source or USB port.
2. Insert a battery into the charging bay.
3. Monitor the charging status LEDs until charging is complete.

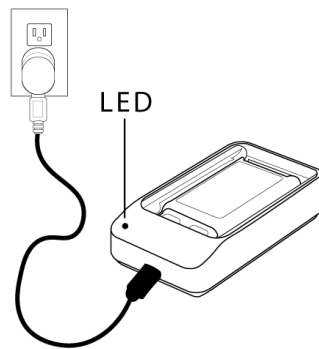

## Charging Status LEDs

Description	Color	State
<b>Ready for Use</b>	Green (solid)	Device is fully charged
<b>Charging</b>	Red (flashing)	Charging
<b>Error</b>	Yellow (quick flashing)	Battery or power supply error
<b>Not charging</b>	Off	Power supply is disconnected, or no device is docked in the charging bay

## Dual Bay Chargers

The SBC203 dual-bay charger can charge individual batteries or batteries installed in transmitters.

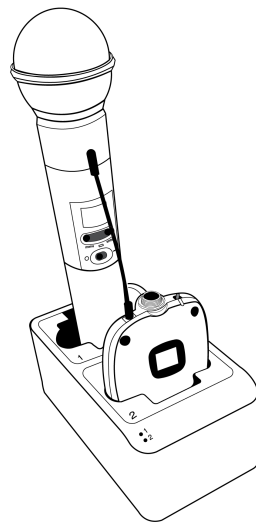

1. Plug the charger into an AC power source.
2. Insert batteries or transmitters into the charging bay.

**IMPORTANT:** Insert transmitters facing forward to avoid damage.

3. Monitor the charging status LEDs until charging is complete.

## Charging Status LEDs

Description	Color	State
<b>Ready for Use</b>	Green (solid)	Device is fully charged
<b>Charging</b>	Red (flashing)	Charging
<b>Error</b>	Yellow (quick flashing)	Battery or power supply error*
	<b>Yellow (slow flashing)</b>	Outside of operating temperature range
<b>Not charging</b>	Off	Power supply is disconnected, or no device is docked in the charging bay

\* If an error occurs when a transmitter is docked in the charger, remove the battery from the transmitter and place directly into the charger. If the error persists, contact Shure Technical Support.

## SBC80-903 Battery Charger

The SBC80-903 cradle charger holds eight SB903 batteries and is designed to fit into a rackmount drawer. It may be used in any appropriate location with adequate space and ventilation.

## Power

1. Connect DC power cable to input jack on back of charger.
2. Finger tighten lock nut for a secure connection.
3. Connect power cable to AC Adapter.

### WARNING:

- Do not use pliers or any other tools to tighten lock nut. DC power cable must be attached before charger unit is installed.
- Do not plug in power supply unit until DC connection and charger are in place.
- After securing the charger, plug the power cable into a properly grounded outlet.

The SBC80-903 has no power switch. When plugged in, the charger is ready. The LEDs illuminate after batteries are inserted.

## Charging Status LEDs

To charge, place batteries into the charging bays with slotted sides down. The LEDs illuminate to indicate battery status.

### Charging Status LEDs

Description	Color	State
<b>Ready for Use</b>	Green (solid)	Device is fully charged
<b>Charging</b>	Red (flashing)	Charging
<b>Error</b>	Yellow (quick flashing)	Battery or power supply error
	Yellow (slow flashing)	Outside of operating temperature range
<b>Not charging</b>	Off	Power supply is disconnected, or no battery is inserted in the charging bay

## Important Tips for Care and Storage of Shure Rechargeable Batteries

Proper care and storage of Shure batteries results in reliable performance and ensures a long lifetime.

- Always store batteries and transmitters at room temperature
- Ideally, batteries should be charged to approximately 40% of capacity for long-term storage
- During storage, check batteries every 6 months and recharge to 40% of capacity as needed

## Average Charging Times

### SBC10-903

Time Charging	Operating Runtime	Capacity
1 hour	1 hour	15%
3 hours	4 hours	50%
5 hours : 30 minutes	>8 hours	100%

### SBC203

Time Charging	Operating Runtime	Capacity
30 minutes	1 hour	15%
1 hour : 15 minutes	4 hours	50%
2 hours : 30 minutes	>8 hours	100%

### SBC80-903

Time Charging	Operating Runtime	Capacity
30 minutes	1 hour	15%
1 hour : 15 minutes	4 hours	50%
2 hours : 30 minutes	>8 hours	100%

\*based on battery with 100% health

## How to Link SLX-D Transmitters and Receivers

### Creating Audio Channels

A wireless audio channel is formed when a receiver and transmitter are tuned to the same frequency. There are 3 methods for tuning the receiver and transmitter to the same frequency:

- **Group and Channel Scan:** The receiver scans the RF spectrum for the best available frequency and an IR sync automatically tunes the transmitter to the receiver frequency

- **Manual Group, Channel, or Frequency Selection:** Manually set the receiver and transmitter to the same group and channel number, or frequency
- **Guided Frequency Setup:** A step-by-step guide to walk you through the process

**Important!** Before you begin a scan or frequency assignment:

- Connect all the receivers in your system using Ethernet cables. For best results, use a network switch when connecting 3 or more receiver units.
- Turn off all transmitters for the system you are setting up, to prevent interference with frequency scans.
- Turn on any other devices that may cause interference, such as other wireless systems, computers, CD players, large LED panels, and effects processors. This allows the scan to detect and avoid interference from these devices.

## What are Groups and Channels?

To minimize interference, Shure wireless systems organize RF bands into predefined **groups** and **channels**. A group is a set of compatible frequencies within a frequency band. A single frequency within a group is a channel. Tune a receiver and transmitter to the best available channel within its group to set up your system.

**Note:** All receivers in the same band should be set to the same group. Because groups are band-dependent, some systems don't have multiple groups. Single-group bands have the same RF performance as those with multiple groups.

## Group and Channel Scan

Group scan identifies the number of available channels in each group and automatically assigns an available channel within your selected group. Perform a channel scan if you want to find a new channel, or if you are using the manual frequency selection method (see **Manual Frequency Selection**).

**IMPORTANT:** Turn off all transmitters you plan to use with your system.

To perform a group scan:

1. Go to Frequency Setup > Group Scan.
2. Push the control knob to select start scan.
3. After the scan completes, push the control knob to select assign.
4. Turn on the transmitter you plan to use with this receiver.
5. Align the infrared (IR) ports on the transmitter and receiver, then push the sync button.

To perform a channel scan:

1. Go to Frequency Setup > Channel Scan.
2. Push the control knob to select start scan.
3. After the scan completes, push the control knob to select apply.
4. Turn on the transmitter you plan to use with this receiver.
5. Align the infrared (IR) ports on the transmitter and receiver, then push the sync button.

## Manual Frequency Selection

To manually adjust group, channel or frequency:

1. Go to Frequency Setup > Manual Frequency Setup and select and adjust the group (G), channel (C), or frequency (MHz) as needed.
2. Select apply to save your settings.
3. Align the infrared (IR) ports on the transmitter and receiver, then push the sync button.

## Using the Guided Frequency Setup

Use the guided frequency setup to walk through the group and channel scan process.

**Important!** Change the wideband receiver frequency to match the narrowband transmitter frequency when prompted.

To set up a new system:

1. Go to Frequency Setup > Guided Setup > Initialize My System and push the control knob to continue.
2. Turn off all transmitters you plan to use with your system, then push the control knob to select start scan.
3. After the scan completes, push the control knob to select assign.
4. Turn on the transmitter you plan to use with this receiver.
5. Align the infrared (IR) ports on the transmitter and receiver, then push the sync button.

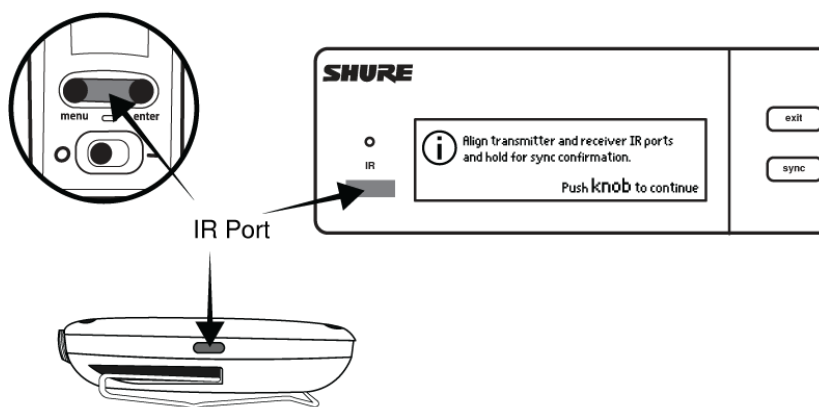

To add a new receiver to your system:

1. Go to Frequency Setup > Guided Setup > Add Receiver to My System and push the control knob to continue.
2. Use the same group number on all receivers in your system. To change the group, rotate the control knob to select the group number, push the knob, rotate to change the number, and push again to confirm.
3. Push the control knob to select start scan.
4. After the scan completes, push the control knob to select apply.
5. Turn on the transmitter you plan to use with this receiver.
6. Align the infrared (IR) ports on the transmitter and receiver, then push the sync button.

## Linking Two Transmitters to a Receiver

Linking two transmitters to a receiver offers the flexibility to provide a performer with either a handheld or bodypack transmitter to meet their preference. For performances requiring instrument changes, two bodypack transmitters can be linked to a single receiver.

**Note:** Only turn on and operate one transmitter at a time to prevent interference between the transmitters.

To link transmitters to the receiver:

1. Turn on the first transmitter and perform an IR Sync with the receiver.
2. Perform a sound check and adjust the transmitter gain if necessary. When finished, turn off the transmitter.
3. Turn on the second transmitter and perform an IR Sync with the receiver.
4. Test the transmitter at performance conditions and adjust the transmitter gain if necessary. When finished, turn off the transmitter.

## Matching Audio Levels with Mic Offset

When linking two transmitters to a receiver, there may be a difference in volume levels between microphones or instruments. If this occurs, use the Mic Offset function to match the audio levels and eliminate audible volume differences between transmitters. If using a single transmitter, set mic offset to 0 dB.

1. Turn on the first transmitter and perform a sound check to test the audio level. Turn off the transmitter when finished.
2. Turn on the second transmitter and perform a sound check to test the audio level.
3. If there is an audible difference in the sound level between the transmitters, navigate to the Mic Offset menu on the transmitter to increase or decrease the mic offset to match the audio levels.



## Gain Adjustment

Go to **Audio Settings > Gain** to test the transmitter at performance levels. Adjust the gain to keep the audio indicator within the optimal range. Reduce the gain if there is audible distortion of the audio.

**Note:** Recommended gain setting for instruments is -18 dB.

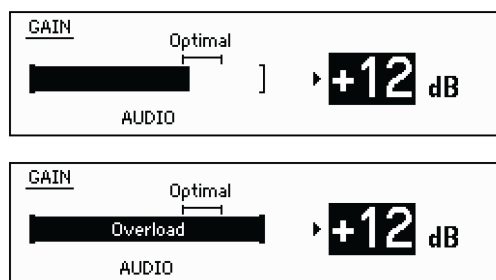

## Audio Summing

Audio summing combines input signals and sends them over a single output channel. This makes it possible to send all channels to a device with a limited number of Dante receiver channels or analog inputs. Summed audio is available on all outputs.

To combine channels, select one of the audio summing options in **Device Configuration > Audio > Audio Summing**.

The following audio summing mode options are available:

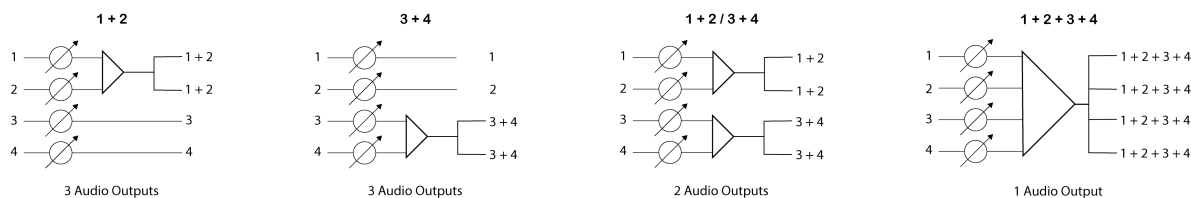

## Radio Frequency (RF) Settings

### How to Use Narrowband Transmitters with a Wideband Receiver

There are two ways to set up the wideband SLXD4Q+ receiver to use with narrowband SLX-D transmitters:

- Before setting up your system, go to **Device Configuration > RF > RF Band** and select the band that matches your transmitter.
- During IR sync, the receiver will detect a band mismatch and open the RF Band menu automatically. Push the control knob to apply the suggested change.

### Setting the Transmitter RF Power

The transmitter offers multiple RF power settings which determine the transmitter range.

- 1 mW (Low)
- 10 mW (High)
- 30 mW (SLXD3 only)

Use the low setting when the transmitter and receiver are in close proximity.

1. Navigate to the transmitter RF power menu.
2. Use the menu button to select an RF power setting.
3. Press enter to save.

### RF Cascade Ports

The receiver has two RF cascade ports on the rear panel to share the signal from the antennas with an additional receiver.

Use a shielded coaxial cable to connect the RF cascade ports from the first receiver to the antenna inputs of the second receiver.

**Important!** The frequency band must be the same for both receivers.

### Antenna Bias

Antenna ports A and B provide a DC bias to power active antennas. Set the DC power to off when using passive (non-powered) antennas.

To turn antenna bias on or off, go to **Device Configuration > RF > Antenna Bias**.

# Connecting to a Network

1. Connect the appropriate network ports to an Ethernet switch using an Ethernet cable (see **Dante Switch Modes** for network connection options).
2. The network port LEDs on the receiver will illuminate to indicate network connectivity and network traffic.

## Network Controllers

You can remotely manage and monitor standard and Dante receivers using Wireless Workbench. Dante receivers allow you to remotely monitor digital audio routing using Dante Controller. Signals for AMX and Crestron controllers are carried on the same network as Shure Control.

### Shure Control

Wireless Workbench (WWB) software provides comprehensive control for wireless audio systems. Wireless Workbench enables live remote adjustments to networked receivers for real-time changes to gain, frequency, RF power, and control locks. The channel strip interface displays audio meters, transmitter parameters, frequency settings and network status.

Wireless Workbench is available for Windows or Mac and can be downloaded at <https://www.shure.com/en-US/products/software/wwb>.

### Dante

Dante Controller is a free software program created by Audinate to configure and manage a network of Dante enabled devices. Use the controller to create audio routes between networked components and to monitor the status of online devices.

Visit <https://www.audinate.com> for download and installation instructions.

## External Control Systems

SLXD4Q+ is compatible with external control systems such as AMX or Crestron via Ethernet. Use only one controller per system to avoid messaging conflicts.

- Connection: Ethernet (TCP/IP; SLX-D receiver is the client)
- Port: 2202

The receiver blocks command strings by default. You can block or allow third-party controls in the Device Configuration > Device Settings > Controller Access menu.

For a comprehensive list of command strings, visit <https://www.shure.com/en-US/docs/commandstrings/SLXD>.

## IP Address Configuration

An IP address must be assigned to each device in the network to ensure communication and control between components. Valid IP addresses can be assigned automatically using a DHCP server or manually from a list of valid IP addresses. If using Dante audio, a separate Dante IP address must also be assigned to the receiver.

### IP Addressing for Standard Receivers

1. Go to Device Configuration > Connectivity > Network Setup > start setup.
2. Use the control knob to select Automatic or Manual. For Manual, enter the IP settings.
3. Press apply to save.

### IP Addressing for Dante Receivers

1. Go to Device Configuration > Connectivity > Network Setup > start setup.
2. Select the switch mode (see **Dante Switch Modes**).

3. Set the Shure control network mode to Automatic or Manual. For Manual, enter the IP settings.
4. Set the Dante primary network mode to Automatic or Manual. For Manual, enter the IP settings.
5. Press apply to save.

## Dante Switch Modes

SLXD4Q+ has two network ports to provide flexible routing and configuration options for network signals.

Three selectable network modes are available to control signal routing from the receiver ports to the network:

<b>Switched mode</b>	<ul style="list-style-type: none"> <li>• Typically used for single network installations of star or daisy-chained networks</li> <li>• Recommended for installations that don't require Dante audio</li> <li>• Dante audio and Shure control are present on both network ports</li> <li>• IP addresses for Dante and Shure control must be on the same subnet</li> </ul>
<b>Redundant mode</b>	<ul style="list-style-type: none"> <li>• Carries a backup copy of the audio on Dante 2 network in case audio on Dante 1 network is interrupted</li> <li>• Dante audio and Shure control are present on the Dante 1 network port</li> <li>• Backup audio is present on the Dante 2 network port</li> <li>• IP addresses for Dante 1 and Shure control must be on the same subnet</li> </ul>
<b>Split mode</b>	<ul style="list-style-type: none"> <li>• Isolates control signals from audio signals by placing them on two separate networks</li> <li>• Shure control is present on the Dante 1 network port</li> <li>• Dante audio is present on the Dante 2 network port</li> <li>• IP addresses for Dante and Shure control must be on different subnets</li> </ul>

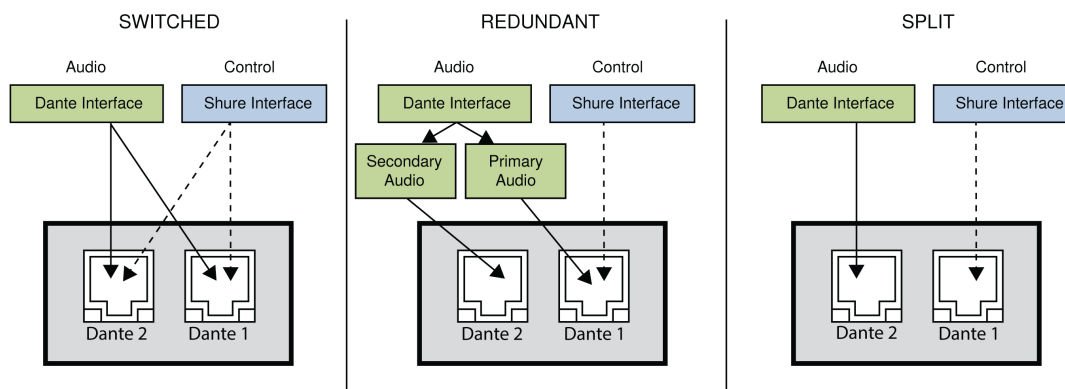

## Setting the Dante Switch Mode

Select a Dante switch mode to configure network signal routing on the Dante ports. Set all receivers on the network to the same mode.

**Note:** Remove network connections from the receiver before changing the mode.

1. Go to Device Configuration > Connectivity > Network Setup > start setup.
2. Select a switch mode.

3. Set the Shure control and Dante network modes as needed.
4. Press apply to save.

## Network Troubleshooting

- Use only one DHCP server per network
- All devices must share the same subnet mask
- All receivers must have the same level of firmware version installed
- Check for the network icon on the display:
  - If the icon is not visible, check the cable connection and the network status LEDs on the back panel.
  - If the LEDs are not on and the cable is plugged in, replace the cable and recheck the LEDs and network icon.

---

## How to Update Firmware

Firmware is embedded software in each component that controls functionality. Periodically, new versions of firmware are developed to incorporate additional features and enhancements. To take advantage of design improvements, new versions of the firmware can be uploaded and installed using the Shure Update Utility (SUU). Download the SUU from [https://www.shure.com/en-US/products/software/shure\\_update\\_utility](https://www.shure.com/en-US/products/software/shure_update_utility).

To update the firmware:

**CAUTION!** Ensure the device has a stable network connection during the update. Do not turn off the device until the update is complete.

1. Connect the device and computer to the same network (set to the same subnet).
2. Open the SUU application.
3. Click the updates button at the top of the window to open the Download Manager.

**Note:** This button will be labeled either "Check for updates..." or "[#] updates available"

4. From the Download Manager, select the desired firmware versions.
5. Click Download, and then close the Download Manager. Downloaded firmware is listed and can be viewed and managed in the Firmware tab.
6. From the Update Devices tab, select the new firmware and press Send Updates to begin the firmware update.

## Updating the Transmitter Firmware

1. Use the receiver control knob to go to Device Configuration > Advanced Settings > Transmitter Firmware.
2. Align the infrared (IR) port on the transmitter with that on the receiver, and push the sync button.

**Important:** Alignment must be maintained during the entire update cycle.

3. Once the sync is complete, the system is ready for use.

## Firmware Version Requirements

The recommended best practice is that all devices are on an identical firmware version. To view the firmware version of each device on the network, go to Device Configuration > About.

The format for Shure device firmware is MAJOR.MINOR.PATCH.BUILD (example: 1.2.21.1). At a minimum, all devices on the same network must have identical MAJOR and MINOR firmware version numbers (example: 1.2.x.x).

# Rack Mounting the Receiver

All accessories are supplied:

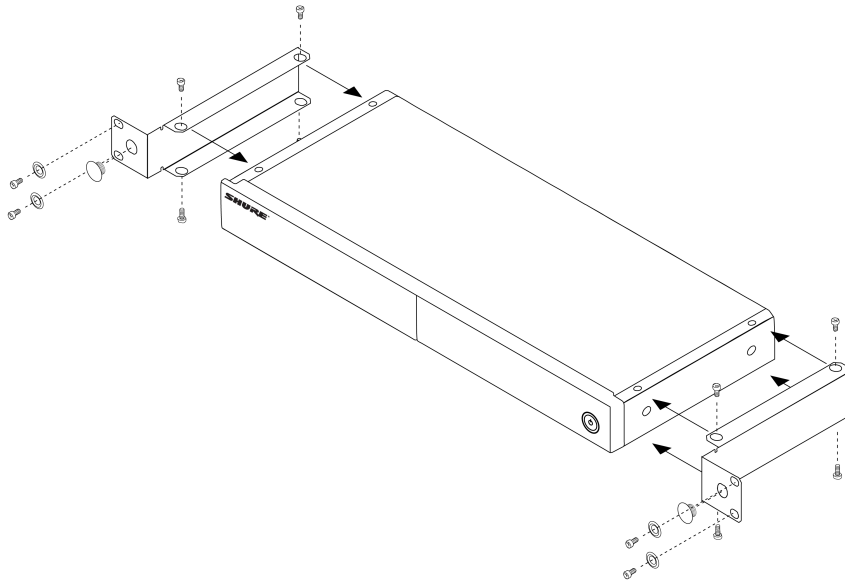

## Installing Footpads

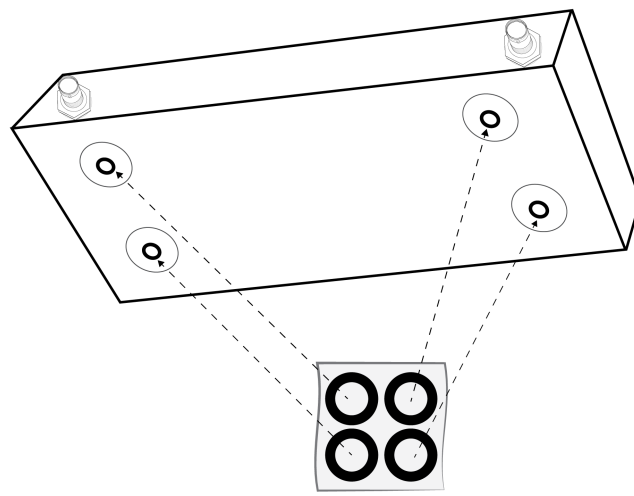

## Optional Accessories

### Batteries and Chargers

<b>Shure Lithium-Ion Rechargeable Battery</b>	SB903
<b>8-Bay Cradle Charger</b>	SBC80-903-AR

	<b>SBC80-903-AZ</b>
	<b>SBC80-903-BR</b>
	<b>SBC80-903-CN</b>
	<b>SBC80-903-E</b>
	<b>SBC80-903-IN</b>
	<b>SBC80-903-J</b>
	<b>SBC80-903-K</b>
	<b>SBC80-903-TW</b>
	<b>SBC80-903-UK</b>
	<b>SBC80-903-US</b>
<b>Dual Docking Charger</b>	SBC203-AR
	<b>SBC203-AZ</b>
	<b>SBC203-BR</b>
	<b>SBC203-CN</b>
	<b>SBC203-E</b>
	<b>SBC203-IN</b>
	<b>SBC203-J</b>
	<b>SBC203-K</b>
	<b>SBC203-TW</b>
	<b>SBC203-UK</b>
	<b>SBC203-US</b>
<b>Single Battery Charger</b>	SBC10-903-AR
	<b>SBC10-903-AZ</b>
	<b>SBC10-903-BR</b>
	<b>SBC10-903-CN</b>
	<b>SBC10-903-E</b>
	<b>SBC10-903-IN</b>
	<b>SBC10-903-J</b>
	<b>SBC10-903-K</b>
	<b>SBC10-903-TW</b>

	<b>SBC10-903-UK</b>
	<b>SBC10-903-US</b>

## UHF Antenna Power Distribution Amplifiers

<b>Antenna/Power Distribution System 470-960 MHz</b>	UA844+SWB
	<b>UA844+SWB-AR</b>
	<b>UA844+SWB-AZ</b>
	<b>UA844+SWB-BR</b>
	<b>UA844+SWB-C</b>
	<b>UA844+SWB-E</b>
	<b>UA844+SWB-J</b>
	<b>UA844+SWB-K</b>
	<b>UA844+SWB-TW</b>
	<b>UA844+SWB-UK</b>
	<b>UA844+SWB-IN</b>
<b>Antenna/Power Distribution System, Less cable 470-960 MHz</b>	UA844+SWB/LC
	<b>UA844+SWB/LC-AR</b>
	<b>UA844+SWB/LC-BR</b>
	<b>UA844+SWB/LC-C</b>
	<b>UA844+SWB/LC-E</b>
	<b>UA844+SWB/LC-UK</b>
<b>Ultra Wideband Antenna/Power Distribution System 174-1805 MHz</b>	UA845UWB
	<b>UA845UWB-AR</b>
	<b>UA845UWB-AZ</b>
	<b>UA845UWB-BR</b>
	<b>UA845UWB-C</b>
	<b>UA845UWB-E</b>
	<b>UA845UWB-IN</b>
	<b>UA845UWB-J</b>
	<b>UA845UWB-K</b>
	<b>UA845UWB-TW</b>

	<b>UA845UWB-UK</b>
<b>Ultra Wideband Antenna/Power Distribution System, Less cable 174-1805 MHz</b>	UA845UWB/LC
	<b>UA845UWB/LC-AR</b>
	<b>UA845UWB/LC-BR</b>
	<b>UA845UWB/LC-E</b>
	<b>UA845UWB/LC-UK</b>

## UABIAST

<b>In-Line Power Supply</b>	UABIAST-US
	<b>UABIAST-UK</b>
	<b>UABIAST-BR</b>
	<b>UABIAST-AR</b>
	<b>UABIAST-E</b>
	<b>UABIAST-CHN</b>
	<b>UABIAST-IN</b>
	<b>UABIAST-K</b>
	<b>UABIAST-J</b>
	<b>UABIAST-AZ</b>
<b>UABIAST-TW</b>	

## In-Line Amplifiers and Antennas

<b>In-Line Antenna Amplifier, 470-900 MHz</b>	UA834WB
<b>In-Line Antenna Amplifier, 902-960 MHz</b>	UA834XA
<b>Active Directional Antenna 470-790 MHz</b>	UA874E
<b>Active Directional Antenna 470-698 MHz</b>	UA874US
<b>Active Directional Antenna 470-900 MHz</b>	UA874WB
<b>Active Directional Antenna 925-952 MHz</b>	UA874X
<b>Directional Wideband Antenna for PSM Systems 470-952 MHz</b>	PA805SWB
<b>Directional Wideband Antenna for PSM Systems 650-1100 MHz</b>	PA805X
<b>Passive Omnidirectional Antenna 470-1100 MHz</b>	UA860SWB

<b>UHF Passive Antenna Splitter</b>	UA221
<b>Front Mount Antenna Kit (Includes 2 Cables And 2 Bulk-head)</b>	UA600
<b>Remote Antenna Bracket With BNC Bulkhead Adaptor</b>	UA505
<b>Helical Antenna, 470-900MHZ</b>	HA-8089

## Cables, Cases and Connectors

<b>Coaxial Cable, BNC-BNC, RG58C/U TYPE, 50 OHM, 2 FT Length (0.6 M)</b>	UA802
<b>Coaxial Cable, BNC-BNC, RG58C/U TYPE, 50 OHM, 6 FT Length (2 M)</b>	UA806
<b>Coaxial Cable, BNC-BNC, RG8X/U TYPE, 50 OHM, 25 FT Length (7.5 M)</b>	UA825
<b>Coaxial Cable, BNC-BNC, RG8X/U TYPE, 50 OHM, 50 FT Length (15 M)</b>	UA850
<b>Coaxial Cable, BNC-BNC, RG213/U TYPE, 50 OHM, 100 FT Length (30 M)</b>	UA8100
<b>Ethernet Jumper Cable, 8"</b>	C8006
<b>Ethernet Cable, 3 FT.</b>	C803
<b>Ethernet Cable, 10 FT.</b>	C810
<b>Ethernet Cable, Ruggedized, 25 FT.</b>	C825
<b>Ethernet Cable, Ruggedized, 50 FT.</b>	C850
<b>Ethernet Cable, Ruggedized, 100 FT.</b>	C8100

## 1/2 Wave Omnidirectional Receiver Antennas

<b>470-542 MHz</b>	UA8-470-542
<b>500-560 MHz</b>	UA8-500-560
<b>518-598 MHz</b>	UA8-518-598
<b>554-638 MHz</b>	UA8-554-638
<b>596-698 MHz</b>	UA8-596-698
<b>670-742 MHz</b>	UA8-670-742
<b>690-746 MHz</b>	UA8-690-746
<b>694-758 MHz</b>	UA8-694-758
<b>710-790 MHz</b>	UA8-710-790

740-814 MHz	UA8-740-814
750-822 MHz	UA8-750-822
774-865 MHz	UA8-774-865
00-1000 MHz	UA8-900-1000

## Specifications

### System RF

#### RF Carrier Frequency Range

470–937.5 MHz, varies by region (See Frequency Range and Output Power table)

#### Working Range

100 m ( 328 ft)

Note: Actual range depends on RF signal absorption, reflection and interference.

#### RF Tuning Step Size

25 kHz, varies by region

JB band: 125 kHz

#### Image Rejection

>85 dB, typical

#### RF Sensitivity

-97 dBm at  $10^{-5}$  BER

### System Temperatures

#### Operating Temperature Range

-18°C (0°F) to 50°C (122°F)

Note: Battery characteristics may limit this range.

#### Storage Temperature Range

-29°C (-20°F) to 74°C (165°F)

Note: Battery characteristics may limit this range.

### System Audio

#### Latency

3.2 ms

**High-Pass / Low Cut Filter**

150 Hz @ -12 db/oct

Note: Factory default is for the HPF to be off

**Audio Dynamic Range**

118 dB at 1% THD, A-weighted, typical

**Total Harmonic Distortion**

&lt;0.02%

**System Audio Polarity**

Positive pressure on microphone diaphragm produces positive voltage on pin 2 with respect to pin 3 of XLR output and the tip of the 6.35 mm (¼ inch) with respect to the ring of the 6.35 mm output.

**Mic Offset Range**

0 to 21 dB (in 3 dB steps)

**SLXD4Q+ Receiver****Dimensions**

42 x 393 x 152 mm (1.65 x 15.47 x 5.98 in.), H x W x D

**Weight**

1750 g, without antennas

**Housing**

Galvanized Steel

**Power Requirements**

<b>Maximum power draw with Dante</b>	15 V at 1030 mA
<b>Maximum power draw without Dante</b>	15 V at 900 mA

**RF Input****Spurious Rejection**

&gt;75 dB, typical

**Connector Type**

BNC

**Impedance**

50 Ω

**Bias Voltage**

15 V DC, 150 mA maximum, per antenna

switchable on-off

## Audio Output

### Audio Frequency Response

20 Hz– 20 kHz (+1, -2 dB)

### Gain Adjustment Range

-18 to +42 dB in 1 dB steps

### Configuration

<b>1/4" (6.35 mm)</b>	Balanced (Tip = audio +, Ring = audio -, Sleeve = ground )
<b>XLR</b>	Balanced (1=ground, 2=audio +, 3=audio -)

### Impedance

<b>1/4" (6.35 mm)</b>	1.1 k $\Omega$ (550 $\Omega$ Unbalanced)
<b>XLR (line)</b>	500 $\Omega$ (250 $\Omega$ Unbalanced)
<b>XLR (mic)</b>	150 $\Omega$

### Full Scale Output

<b>1/4" (6.35 mm)</b>	+12 dBV Unbalanced, +18 dBV Balanced
<b>XLR</b>	LINE setting= +18 dBV, MIC setting= -12 dBV

### Mic/Line Switch

30 dB pad

### Phantom Power Protection

<b>1/4" (6.35 mm)</b>	Yes
<b>XLR</b>	Yes

## Cascade Output

### Connector Type

BNC

Note: For connection of one additional receiver in the same band

### Configuration

Unbalanced

### Impedance

50  $\Omega$

### Insertion Gain

0–2 dB, typical

---

## Networking

### Network Interface

10/100 Mbps, 1 Gbps, Dante Digital Audio

### Network Addressing Capability

DHCP or Manual IP address

### Maximum Cable Length

100 m (328 ft)

## SLXD1 Bodypack Transmitter

### Battery Type

Rechargeable Li-Ion or 1.5 V AA batteries

### Dimensions

98 x 68 x 25.5 mm (3.86 x 2.68 x 1 in.), H x W x D

### Weight

89 g

### Housing

PC/ABS

## Audio Input

### Connector

4-Pin male mini connector (TA4M)

### Configuration

See drawing for details

### Impedance

1 M $\Omega$

### Maximum Input Level

8.2 dBV (2.57 Vrms, 7.27 Vpp)

### Preamplifier Equivalent Input Noise (EIN)

-118 dBV

## RF Output

### Antenna Type

1/4 wave

---

### Occupied Bandwidth

<200 kHz

### Modulation Type

Shure proprietary digital

### Power

1 mW or 10 mW

See Frequency Range and Output Power table, varies by region

## SLXD2 Handheld Transmitter

### Battery Type

Rechargeable Li-Ion or 1.5 V AA batteries

### Dimensions

37.1 x 176 mm (1.46 x 6.93 in.), D x L

### Weight

147 g

### Housing

Aluminum

### Audio Input

### Configuration

See drawing for details

### Maximum Input Level

8.2 dBV (2.57 V<sub>rms</sub>, 7.27 V<sub>pp</sub>)

Note: Dependent on microphone type

## RF Output

### Antenna Type

Integrated Single Band Helical

### Occupied Bandwidth

<200 kHz

### Modulation Type

Shure proprietary digital

### Power

1 mW or 10 mW

See Frequency Range and Output Power table, varies by region

## SLXD3 Plug-On Transmitter

### Battery Type

Rechargeable Li-Ion or 1.5 V AA batteries

### Dimensions

126 × 41 × 41 mm (4.96 × 1.61 × 1.61 in.), L×W×D

### Weight

200 g

### Housing

Aluminum, zinc alloy, PC/ABS

## Audio Input

### Connector Type

XLR

See drawing for details

### Maximum Input Level

<b>Pad -12 dB</b>	20.5 dBV
<b>0 dB</b>	8.5 dBV
<b>Boost +12 dB</b>	-3.5 dBV

1 kHz at 1% THD

Note: Dependent on microphone type

### Phantom Power

+48 V(7 mA maximum), +12 V(15 mA maximum)

## RF Output

### Antenna Type

Dipole

### Occupied Bandwidth

<200 kHz

### Modulation Type

Shure proprietary digital

### Power

1 mW / 10 mW / 30 mW

See Frequency Range and Output Power table, varies by region

### Specific Absorption Rate (SAR)

< 0.17 W/kg

### SB903 Rechargeable Battery

#### Charge Voltage

4.2 V ( $\pm 0.03$  V)

#### Charge Current

<b>SBC10-903</b>	220 mA
<b>SBC203</b>	625 mA (normal), 250 mA (reduced)*
<b>SLXD3</b>	650 mA

\* Normal = 10 °C to 45 °C (50 °F to 113 °F), reduced = 0 °C to 10 °C (32 °F to 50 °F)

#### Nominal Voltage

3.6 V

#### Nominal Capacity

1200 mAh

#### Housing

Molded Polycarbonate

#### Charging Temperature Range

0 °C to 45 °C (32 °F to 113 °F)

#### Dimensions

14.5 x 32.5 x 55.5 mm (0.57 x 1.28 x 2.19 in.), H x W x D

#### Weight

28 g

### SBC10-903 Battery Charger

#### DC Input Voltage Range

5 V DC

#### Charge Current

*USB-powered*

220 mA

#### Charge Time

50% = 3 hours; 100% = 5 hours : 30 minutes

---

## External Power Supply

SBC10-USB

## Power Requirements

5 V DC, 1 A max.

## Operating Temperature Range

0 °C to 45 °C (32 °F to 113 °F)

## Dimensions

20.5 x 37.5 x 79.5 mm (0.81 x 1.48 x 3.13 in.), H x W x D

## Weight

39 g

## Housing

Molded Polycarbonate

## SBC203 Battery Charger

## Charge Current

625 mA or 250 mA

Lower current used when using another power source, or operating between 0°C and 10°C

## Charge Time

50% = 1 hour : 15 minutes; 100% = 2 hours : 30 minutes

## External Power Supply

SBC10-USB15W or SBC10-USB15WS

## Power Requirements

5 V DC, 3 A max.

## Operating Temperature Range

0 °C to 45 °C (32 °F to 113 °F)

## Dimensions

66.3 x 86.0 x 155 mm (2.61 x 3.38 x 6.13 in.), H x W x L

## Weight

284 g

## Housing

ABS

## SBC80-903 8-Bay Battery Charger

### Charge Current

625mA

### Charge Time

50%=1 hour; 100%=3 hours

### External Power Supply

PS60

### Power Requirements

15V DC, 4A

### Dimensions

30 mm x 173 mm x 146 mm (1.18 in. x 6.81 in. x 5.75 in.), H x W x D

### Weight

375 g (13.2 oz.)

### Storage Temperature Range

-20°F to 165°F (-29°C to 74°C)

### Charging Temperature Range

32°F to 113°F (0°C to 45°C)

## Receiver Output Connectors

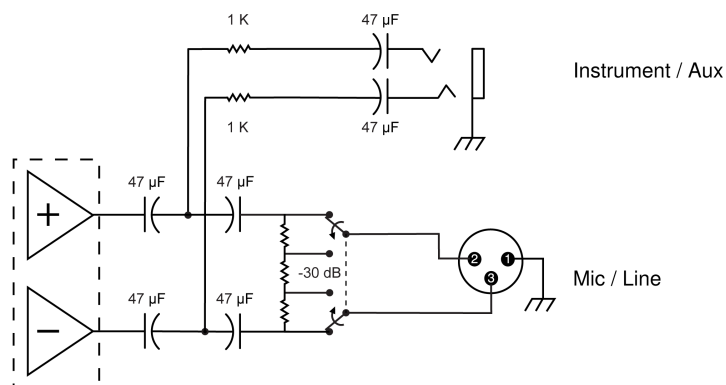

## Transmitter Input

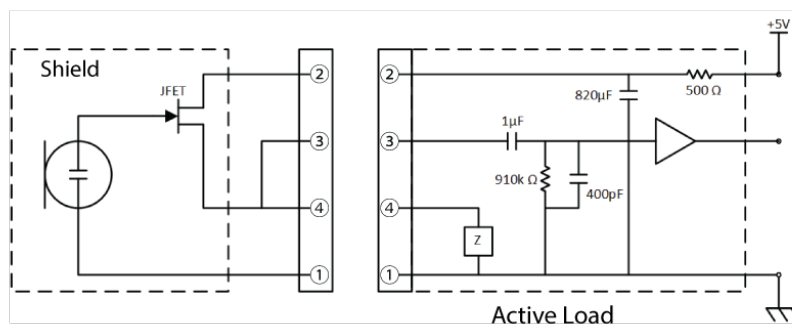

- 1: Ground
- 2: Bias Voltage
- 3: Audio Input
- 4: Active Load

SLXD1/SLXD2

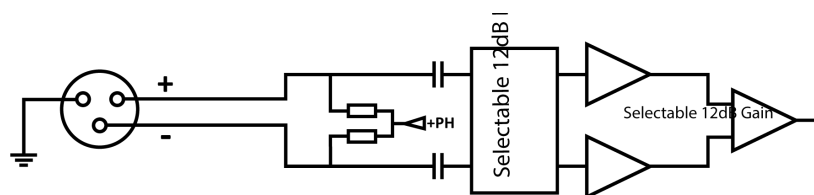

SLXD3

## Frequency Range and Transmitter Output Power

Band	Frequency Range (MHz)	Power ( mW RMS )* (Low/High)
G54	479 to 565	1 / 10
G57	470 to 608	1 / 10 / 30**
G60	470 to 510	1 / 10 / 30**
G64	470 to 616	1 / 10 / 30**
G65	470 to 606	1 / 10 / 30**
G66	487 to 606	1 / 10
H58	520 to 608	1 / 10 / 30**

Band	Frequency Range (MHz)	Power ( mW RMS )* (Low/High)
JB	806 to 810	1 / 10
K55	606 to 694	1 / 10 / 30**
K60	614 to 703	1 / 10
L60	630 to 698	1 / 10 / 30**
M55	694 to 703, 748 to 758	1 / 10 / 30**
S50	823 to 832, 863 to 865	1 / 10
X51	925 to 937.5	1 / 10

\* Power delivered to the antenna port

\*\* SLXD3 only

**Note:** Frequency bands might not be available for sale or authorized for use in all countries or regions.

## Frequencies for European Countries



	Frequency Range	Country Code
SLXD-G60	470 - 510 MHz*	
SLXD-G65	470 - 606 MHz*	A, B, BG, CH, CY, CZ, D, EST, F, GB, GR, H, I, IS, L, LT, NL, P, PL, S, SK, SLO, DK, FIN, M, N, HR, E, IRL, LV, RO, TR
SLXD-K55	606–694 MHz*	
SLXD-S50	823–832, 863–865 MHz *	

\* This equipment may be capable of operating on some frequencies not authorized in your region.

## Safety and Regulatory Information for Wireless Products

### Explanation of Symbols

	This symbol indicates that dangerous voltage constituting a risk of electric shock is present within this unit.
	This symbol indicates that there are important operating and maintenance instructions in the literature accompanying this unit.

# Important Safety Instructions

1. READ these instructions.
2. KEEP these instructions.
3. HEED all warnings.
4. FOLLOW all instructions.
5. DO NOT use this apparatus near water.
6. CLEAN ONLY with dry cloth.
7. DO NOT block any ventilation openings. Allow sufficient distances for adequate ventilation and install in accordance with the manufacturer's instructions.
8. DO NOT install near any heat sources such as open flames, radiators, heat registers, stoves, or other apparatus (including amplifiers) that produce heat. Do not place any open flame sources on the product.
9. DO NOT defeat the safety purpose of the polarized or grounding type plug. A polarized plug has two blades with one wider than the other. A grounding type plug has two blades and a third grounding prong. The wider blade or the third prong are provided for your safety. If the provided plug does not fit into your outlet, consult an electrician for replacement of the obsolete outlet.
10. PROTECT the power cord from being walked on or pinched, particularly at plugs, convenience receptacles, and the point where they exit from the apparatus.
11. ONLY USE attachments/accessories specified by the manufacturer.
12. USE only with a cart, stand, tripod, bracket, or table specified by the manufacturer, or sold with the apparatus. When a cart is used, use caution when moving the cart/apparatus combination to avoid injury from tip-over.



13. UNPLUG this apparatus during lightning storms or when unused for long periods of time.
14. REFER all servicing to qualified service personnel. Servicing is required when the apparatus has been damaged in any way, such as power supply cord or plug is damaged, liquid has been spilled or objects have fallen into the apparatus, the apparatus has been exposed to rain or moisture, does not operate normally, or has been dropped.
15. DO NOT expose the apparatus to dripping and splashing. DO NOT put objects filled with liquids, such as vases, on the apparatus.
16. The MAINS plug or an appliance coupler shall remain readily operable.
17. The airborne noise of the Apparatus does not exceed 70dB (A).
18. Apparatus with CLASS I construction shall be connected to a MAINS socket outlet with a protective earthing connection.
19. To reduce the risk of fire or electric shock, do not expose this apparatus to rain or moisture.
20. Do not attempt to modify this product. Doing so could result in personal injury and/or product failure.
21. Operate this product within its specified operating temperature range.
22. Follow local regulations and consult qualified personnel if the product installation or relocation requires construction work. Choose mounting hardware and an installation location that can support the weight of the product. Avoid locations subject to constant vibration. Use the required tools to install the product properly. Inspect the product periodically.

## WARNING:

- Voltages in this equipment are hazardous to life. No user-serviceable parts inside. Refer all servicing to qualified service personnel. The safety certifications do not apply when the operating voltage is changed from the factory setting.
- If water or other foreign objects enter the inside of the device, fire or electric shock may result.

# Safety and Regulatory Information for Battery Chargers

1. This equipment is intended to be used in professional audio applications.
2. Use this battery charger only with the Shure charging modules and battery packs for which it is designed. Use with other than the specified modules and battery packs may increase the risk of fire or explosion.
3. Changes or modifications not expressly approved by Shure Incorporated could void your authority to operate this equipment.

---

## Safety Information for Batteries

1. Battery packs may explode or release toxic materials. Risk of fire or burns. Do not open, crush, modify, disassemble, heat above 140°F (60°C), or incinerate.
2. Follow instructions from manufacturer
3. Only use Shure charger to recharge Shure rechargeable batteries

**WARNING:**

Danger of explosion if battery incorrectly replaced. Replace only with same or equivalent type.

Do not dispose of the battery along with household waste. Check with local vendor for proper disposal of used battery packs.

4. Never put batteries in mouth. If swallowed, contact your physician or local poison control center
5. In the event of a cell leaking, do not allow the liquid to come in contact with the skin or eyes. If contact has been made, wash the affected area with copious amounts of water and seek medical advice.
6. Do not short circuit; may cause burns or catch fire
7. Do not charge or use battery packs other than Shure rechargeable batteries
8. Batteries (battery pack or batteries installed) shall not be exposed to excessive heat such as sunshine, fire or the like
9. Do not immerse the battery in liquid such as water, beverages, or other fluids.
10. Do not attach or insert battery with polarity reversed.
11. Keep away from small children.
12. Do not use abnormal batteries.
13. Pack the battery securely for transport.

**Note:** Use only with the included power supply, batteries, or a Shure-approved equivalent.

## Storing Batteries

If batteries are to be stored for more than eight days, they should be placed into a temperature controlled storage area. Recommended battery storage temperature is 10 to 25°C (50 to 77°F).

Additional battery storage information is available at [shure.com/battery-storage](http://shure.com/battery-storage).



---

## Important Product Regulatory Information

EMC conformance testing is based on the use of supplied and recommended cable types. The use of other cable types may degrade EMC performance.

### Regulatory Information for Class B EMC Products

#### CE Notice

Hereby, Shure Incorporated declares that this product with CE Marking has been determined to be in compliance with European Union requirements.

The full text of the EU declaration of conformity is available at the following site: <https://www.shure.com/en-EU/support/declarations-of-conformity>.

#### UKCA Notice

Hereby, Shure Incorporated declares that this product with UKCA Marking has been determined to be in compliance with UK-CA requirements.

The full text of the UK declaration of conformity is available at the following site: <https://www.shure.com/en-GB/support/declarations-of-conformity>.

#### UK Cybersecurity

##### **UK SI 2023 NO. 1007 STATEMENT OF COMPLIANCE**

**Product Type:** Relevant connectable products as defined by The Product Security and Telecommunications Infrastructure (Security Requirements for Relevant Connectable Products) Regulations 2023.

**Manufacturer Statement:** We, Shure Incorporated, certify and declare as manufacturer under our sole responsibility, that the above mentioned product(s) conform(s) to Schedule 2 of the essential requirements of the listed applicable United Kingdom Statutory Instruments (including their amendments) and the associated norms.

**Information on how to report security issues:** The latest version of Shure's Disclosure policy can be found at the following link: <https://www.shure.com/en-GB/about-us/security>

**Security update periods:** Shure provides support regarding hardware and software updates that continue the integral cyber security safety of Shure products up to 24 months after end of life (AEOL). For the full statement regarding Shure's product support policy, and information regarding products end of life status information can be found at the following link: <https://www.shure.com/en-GB/about-us/security>

**Manufacturer:**

Shure Incorporated 5800 Touhy Avenue  
Niles, Illinois, 60714-4608 U.S.A.  
Website: [www.Shure.com](http://www.Shure.com).

**Technical documentation is kept at:**

Shure Incorporated, Corporate Global Compliance Engineering Division

**UK Importer/Representative:**

Shure UK Limited  
Unit 2, The IO Centre, Lea Road, Waltham Abbey, Essex, EN9 1AS, U.K.  
Phone: +44 (0)1992 - 703058  
Email: [EMEAsupport@shure.de](mailto:EMEAsupport@shure.de)

**On behalf of Manufacturer:**

Chad Ayers

01 February 2024 Niles, Illinois

Senior Director, Global Compliance

## FCC Notice

This equipment has been tested and found to comply with the limits for a Class B digital device pursuant to Part 15 of the FCC Rules. These limits are designed to provide reasonable protection against harmful interference when the equipment is operated in a residential installation. This equipment generates, uses, and can radiate radio frequency energy and, if not installed and used in accordance with the instructions, may cause harmful interference with radio communications. However, there is no guarantee that interference will not occur in a particular installation. If this equipment does cause harmful interference with radio or television reception, which can be determined by turning the equipment off and on, you are encouraged to try to correct the interference by one or more of the following measures:

- Reorient or relocate the antenna of the radio/television receiver.
- Increase the separation between this equipment and the radio/television receiver.
- Plug the equipment into a different outlet so that the equipment and the radio/television receiver are on different power mains branch circuits.
- Consult a representative of Shure or an experienced radio/television technician for additional suggestions.

This device complies with Part 15 of the FCC Rules. Operation is subject to the following two conditions:

1. This device may not cause harmful interference.
2. This device must accept any interference received, including interference that may cause undesired operation.

**Notice:** The FCC regulations provide that changes or modifications not expressly approved by Shure Incorporated could void your authority to operate this equipment.

For information regarding responsible party and other matters relating to FCC compliance, please contact Shure Incorporated, 5800 W. Touhy Avenue, Niles, Illinois 60714-4608 U.S.A. [shure.com/contact](http://shure.com/contact)

## Canada, ISED Notice

**Notice:** The Industry Canada regulations provide that changes or modifications not expressly approved by Shure Inc. could void your authority to operate this equipment.

This Class B digital apparatus complies with Canadian ICES-003. Cet appareil numérique de la classe B est conforme à la norme NMB-003 du Canada.

## Regulatory Information for Wireless Products

This equipment complies with FCC radiation exposure limits set forth for an uncontrolled environment. End user must follow the specific operating instructions for satisfying RF exposure compliance. This transmitter must not be co-located or operating in conjunction with any other antenna or transmitter.

This equipment complies with FCC radiation exposure limits set forth for an uncontrolled environment. This equipment should be installed and operated with minimum distance 20 cm between the radiator & your body.

This equipment complies with FCC radiation exposure limits set forth for an uncontrolled environment. End user must follow the specific operating instructions for satisfying RF exposure compliance. This transmitter must not be co-located or operating in conjunction with any other antenna or transmitter.

The portable device is designed to meet the requirements for exposure to radio waves established by the Federal Communications Commission (USA). These requirements set a SAR limit of 1.6 W/kg averaged over one gram of tissue. The highest SAR value reported under this standard during product certification for use when properly worn on the body/head. This equipment should be installed and operated with minimum distance 0 cm between the radiator and your body/head.

## Industry Canada (IC) Notices

This device contains licence-exempt transmitter(s)/receiver(s) that comply with Innovation, Science and Economic Development Canada's licence-exempt RSS(s). Operation is subject to the following two conditions:

1. This device may not cause interference.
2. This device must accept any interference, including interference that may cause undesired operation of the device.

L'émetteur/récepteur exempt de licence contenu dans le présent appareil est conforme aux CNR d'Innovation, Sciences et Développement économique Canada applicables aux appareils radio exempts de licence. L'exploitation est autorisée aux deux conditions suivantes :

1. L'appareil ne doit pas produire de brouillage;
2. L'appareil doit accepter tout brouillage radioélectrique subi, même si le brouillage est susceptible d'en compromettre le fonctionnement.

This equipment complies with ISED radiation exposure limits set forth for an uncontrolled environment. End user must follow the specific operating instructions for satisfying RF exposure compliance. This transmitter must not be co-located or operating in conjunction with any other antenna or transmitter.

Cet équipement est conforme aux limites d'exposition aux rayonnements ISED établies pour un environnement non contrôlé. L'utilisateur final doit suivre les instructions spécifiques pour satisfaire les normes. Cet émetteur ne doit pas être co-implanté ou fonctionner en conjonction avec toute autre antenne ou transmetteur.

This equipment complies with ISED radiation exposure limits set forth for an uncontrolled environment. End user must follow the specific operating instructions for satisfying RF exposure compliance. This transmitter must not be co-located or operating in conjunction with any other antenna or transmitter. The antenna(s) must be installed such that a minimum separation distance of 20 cm is maintained between the radiator (antenna) and all persons at all times.

Cet équipement est conforme aux limites d'exposition aux rayonnements ISED établies pour un environnement non contrôlé. L'utilisateur final doit suivre les instructions spécifiques pour satisfaire les normes. Cet émetteur ne doit pas être co-implanté ou fonctionner en conjonction avec toute autre antenne ou transmetteur. La ou les antennes doivent être installées de telle façon

qu'une distance de séparation minimum de 20 cm soit maintenue entre le radiateur (antenne) et toute personne à tout moment.

This equipment complies with ISED radiation exposure limits set forth for an uncontrolled environment. This equipment could be installed and operated with minimum distance 0 cm between the radiator and your body. End user must follow the specific operating instructions for satisfying RF exposure compliance. This transmitter must not be co-located or operating in conjunction with any other antenna or transmitter.

The portable device is designed to meet the requirements for exposure to radio waves established by the ISED. These requirements set a SAR limit of 1.6 W/kg averaged over one gram of tissue. The highest SAR value reported under this standard during product certification for use when properly worn on the body/head.

Cet équipement est conforme aux limites d'exposition aux rayonnements ISED établies pour un environnement non contrôlé. Cet équipement peut-être installé et utilisé avec une distance minimale de 0 cm entre le radiateur et votre corps. L'utilisateur final doit suivre les instructions spécifiques pour satisfaire les normes. Cet émetteur ne doit pas être co-implanté ou fonctionner en conjonction avec toute autre antenne ou transmetteur.

Le dispositif portatif est conçu pour répondre aux exigences d'exposition aux ondes radio établie par le développement énergétique DURABLE. Ces exigences un SAR limite de 1,6 W/kg en moyenne pour un gramme de tissu. La valeur SAR la plus élevée signalée en vertu de cette norme lors de la certification de produit à utiliser lorsqu'il est correctement porté sur les corps/tête.

Additional Canadian information on RF exposure also can be found at the following Web address: <http://www.ic.gc.ca/eic/site/smt-gst.nsf/eng/sf08792.html>

## ANATEL Notice

Este equipamento não tem direito à proteção contra interferência prejudicial e não pode causar interferência em sistemas devidamente autorizados. Para maiores informações, consulte o site da ANATEL – <http://www.anatel.gov.br>.

## IFETEL Notice

La operación de este equipo está sujeta a las siguientes dos condiciones: (1) es posible que este equipo o dispositivo no cause interferencia perjudicial y (2) este equipo o dispositivo debe aceptar cualquier interferencia, incluyendo la que pueda causar su operación no deseada.

## KCC Notice

해당 무선설비는 전파혼신 가능성이 있으므로 인명안전과 관련된 서비스는 할 수 없음

## NBTC Notice

เครื่องโทรคมนาคมและอุปกรณ์นี้มีความสอดคล้องตามมาตรฐานหรือข้อกำหนดทางเทคนิคของ กสทช.

## NCC Notice

Connection and use of this communications equipment is permitted by the Nigerian Communications Commission.

## NCC Notice

低功率射頻器材技術規範

取得審驗證明之低功率射頻器材，非經核准，公司、商號或使用者均不得擅自變更頻率、加大功率或變更原設計之特性及功能。低功率射頻器材之使用不得影響飛航安全及干擾合法通信；經發現有干擾現象時，應立即停用，並改善至無干擾時方得繼續使

用。前述合法通信，指依電信管理法規定作業之無線電通信。低功率射頻器材須忍受合法通信或工業、科學及醫療用電波輻射性電機設備之干擾。

614MHz-703MHz: 使用頻段供其他通訊業務使用時，器材應即停止使用

## SRRC Notice

- (一) 本产品符合“微功率短距离无线电发射设备目录和技术要求”的具体条款和使用场景；
- (二) 不得擅自改变使用场景或使用条件、扩大发射频率范围、加大发射功率（包括额外加装射频功率放大器），不得擅自更改发射天线；
- (三) 不得对其他合法的无线电台（站）产生有害干扰，也不得提出免受有害干扰保护；
- (四) 应当承受辐射射频能量的工业、科学及医疗（ISM）应用设备的干扰或其他合法的无线电台（站）干扰；
- (五) 如对其他合法的无线电台（站）产生有害干扰时，应立即停止使用，并采取措施消除干扰后方可继续使用；
- (六) 在航空器内和依据法律法规、国家有关规定、标准划设的射电天文台、气象雷达站、卫星地球站（含测控、测距、接收、导航站）等军民用无线电台（站）、机场等的电磁环境保护区域内使用微功率设备，应当遵守电磁环境保护及相关行业主管部门的规定。

## ACMA Notice

WARNING: This device operates under an ACMA class license and must comply with all conditions of that license including operating frequencies.

## MIC Notice

### 運用に際しての注意

この機器の使用周波数帯では、電子レンジ等の産業・科学・医療用機器のほか工場の製造ライン等で使用されている移動体識別用の構内無線局（免許を要する無線局）及び特定小電力無線局（免許を要しない無線局）並びにアマチュア無線局（免許を要する無線局）が運用されています。

1. この機器を使用する前に、近くで移動体識別用の構内無線局及び特定小電力無線局並びにアマチュア無線局が運用されていないことを確認して下さい。
2. 万一、この機器から移動体識別用の構内無線局に対して有害な電波干渉の事例が発生した場合には、速やかに使用周波数を変更するか又は電波の発射を停止した上、下記連絡先にご連絡頂き、混信回避のための処置等（例えば、パーティションの設置など）についてご相談して下さい。
3. その他、この機器から移動体識別用の特定小電力無線局あるいはアマチュア無線局に対して有害な電波干渉の事例が発生した場合など何かお困りのことが起きたときは、保証書に記載の販売代理店または購入店へお問い合わせください。代理店および販売店情報は Shure 日本語ウェブサイト <http://www.shure.co.jp> でもご覧いただけます。

### 現品表示記号について

2.4 FH1

現品表示記号は、以下のことを表しています。この無線機器は 2.4GHz 帯の電波を使用し、変調方式は「FH-SS」方式、想定干渉距離は 10m です。2,400MHz~2,483.5MHz の全帯域を使用し、移動体識別装置の帯域を回避することはできません。

# Environmental Regulatory Information

## Waste Electrical and Electronic Equipment (WEEE) Directive



In the European Union and the United Kingdom, this label indicates that this product should not be disposed of with household waste. It should be deposited at an appropriate facility to enable recovery and recycling.

## Registration, Evaluation, Authorization of Chemicals (REACH) Directive

REACH (Registration, Evaluation, Authorization of Chemicals) is the European Union (EU) and the United Kingdom (UK) chemical substances regulatory framework. Information on substances of very high concern contained in Shure products in a concentration above 0.1% weight over weight (w/w) is available upon request.

## Recycling Information

Please consider the environment, electric products and packaging are part of regional recycling schemes and do not belong to regular household waste.

## 中国 RoHS

部件名称	有害物质									
	Pb	Cd	Hg	Cr(VI)	PBB	PBDE	DBP	BBP	DIBP	DEHP
电路模块	X	○	○	○	○	○	○	○	○	○
金属模块	X	○	○	○	○	○	○	○	○	○
线缆及其组件	X	○	○	○	○	○	○	○	○	○
电源适配器*	X	○	○	○	○	○	○	○	○	○
锂电池组*	X	○	○	○	○	○	○	○	○	○

本表格依据 SJ/T11364 的规定编制。

O: 表示该有害物质在该部件所有均质材料中的含量均在 GB/T26572 规定的限量要求以下。

X: 表示该有害物质至少在该部件某一均质材料中的含量超出 GB/T26572 规定的限量要求。

注 1: 本产品大部分的部件采用无害的环保材料制造, 含有有害物质的部件皆因全球技术发展水平的限制而无法实现有害物质的替代。

注 2: 以上未列出的部分, 表明其有害物质含量均满足电器电子产品有害物质限制使用国家标准要求

\*: 表示如果包含部分

## Battery Regulatory Information

### EU and UK Battery Directive



In the European Union and the United Kingdom, this label indicates that the batteries in this product should be collected separately and not be disposed of with household waste. Substances in batteries can have a potential negative impact on health and environment and you have a role in recycling waste batteries thus contributing to the protection, preservation, and improvement of the quality of the environment. You should contact your local authority or retailer for details of the collection and recycling schemes available.

# Certifications

## Regulatory Model Number (RMN)

For regulatory identification purposes your product has been assigned a regulatory model number (RMN). This regulatory model number should not be confused with product number, as below.

<b>RMN: SLXD4Q+</b>	<b>Product Numbers:</b> SLXD4Q+ G54/SLXD4Q+ G57/SLXD4Q+ G60/SLXD4Q+ G64/ SLXD4Q+ G65/SLXD4Q+ G66/SLXD4Q+ H58/SLXD4Q+ JB/SLXD4Q+ K55/SLXD4Q+ K60/ SLXD4Q+ L60/SLXD4Q+ M55/SLXD4Q+ S50/ SLXD4Q+ X51/ SLXD4QDAN+ G54/ SLXD4QDAN+ G57/SLXD4QDAN+ G60/SLXD4QDAN+ G64/SLXD4QDAN+ G65/ SLXD4QDAN+ G66/SLXD4QDAN+ H58/SLXD4QDAN+ JB/SLXD4QDAN+ K55/ SLXD4QDAN+ K60/ SLXD4QDAN+ L60/SLXD4QDAN+ M55/SLXD4QDAN+ S50/ SLXD4QDAN+ X51
---------------------	--

## FCC / IC ID

**CONTAINS FCC ID:** DD4SH-BLE

**CONTAINS IC:** 616A-SHBLE

## Energy Efficiency

### External Power Supply meets:

1. The U.S. Energy Conservation Standards specified in the Code of Federal Regulations at 10 CFR 430 32(w).
2. EU COMMISSION REGULATION (EU) 2019/1782 of 1 October 2019: Ecodesign requirements for External Power Supply.
3. Australian Standard requirements of AS/NZS 4665.1:2005 and AS/NZS 4665.2:2005.

### Battery Charger System meets:

1. The U.S. Energy Conservation Standards specified in the Code of Federal Regulations at 10 CFR 430 32(z)
2. Canada NRCan standard: CAN/CSA-C381.2